

INVITATION FOR BID

THIS FORM MUST BE COMPLETED AND
SIGNED FOR YOUR BID TO BE CONSIDERED VALID.

Address to: Procurement Manager
City of Kingsport
225 W Center Street
Kingsport, TN 37660
Phone (423) 229-9419 or Fax (423) 224-2433

Date Issued: 10/11/20
F.O.B. Kingsport

Total Number of Pages: 61

This sealed bid in the original copy, subject to the terms and conditions on the attachment, will be received by the Procurement Manager until 4:00 P.M., Eastern Time on October 28, 2020, at which time will be publicly opened in the **Council Room, City Hall, 225 W. Center Street, Kingsport, Tennessee.** IN THE LOWER LEFT CORNER OF YOUR ENVELOPE ADDRESSED TO ABOVE, MARK YOUR ENVELOPE "HIGHTOP PASSENGER VANS" AND DATE OF THE BID OPENING.

READ TERMS AND CONDITIONS BEFORE COMPLETING THIS FORM

Item	Quantity	U/I	Description	Unit Price	Total Price
01	3	EA	HIGH TOP VAN, MEDIUM DUTY, 8 PASSENGER AS PER ATTACHED SPECIFICATIONS		
02	1	EA	TRADE IN ALLOWANCE VEHICLE #1914		
03	1	EA	TRADE IN ALLOWANCE VEHICLE # 2370		
04	1	EA	TRADE IN ALLOWANCE VEHICLE # 2371		
05	2	EA	OPTION TO PURCHASE FUTURE VANS WITHIN 24 MONTHS BRAND/MODEL _____		
			Delivery Terms: 1. Delivery no later than _____ business days after acceptance of order which shall be defined as purchase order date. 2. The Fleet Maintenance Department will complete vehicle inspection to insure compliance with specifications within ___15___ business days after delivery. 3. If deficiencies are identified upon inspection, the time frame allowed for vendor to correct deficiencies and return vehicle/equipment to the Fleet Maintenance Department will be ___10___ business days after notified by the Fleet Manager.		

Liquidated Damages:

As actual damages for any delays in delivery of the vehicles/equipment which the bidder is required to perform as per this bid document are difficult to determine, the Bidder shall be liable for and shall pay to the Owner the sum of Fifty Dollars (\$50.00) as fixed, agreed and liquidated damages for each business day of delay per purchase order and not per unit from the number of days stipulated for delivery and for deficiency correction

In compliance with this Invitation for Bid and subject to all conditions thereof, the undersigned agrees, if this bid is accepted within 60 days from the date of the opening, to furnish all of the material/service upon which prices are quoted, delivered at the designated point(s) within the time specified.

- (A) Terms: NET
- (B) Delivery/Job completion within _____ days after notification.
- (C) Specification/Letter of explanation enclosed: YES () NO ()

Handwritten Signature of Authorized Representative

Name of Firm

Date

THIS FORM MUST BE SIGNED TO BE CONSIDERED COMPLETE

TERMS AND CONDITIONS

1. Bids must be submitted on this form only and bear the handwritten signature of an authorized representative of the firm to be considered valid. This is a request for quote and can be faxed to (423)224-2433. No telephone bid(s) will be accepted. Unless otherwise stated by the City, no bidder may withdraw his bid within a period of sixty (60) days after the date set for the reply date.
2. If prices are quoted FOB Kingsport, TN., delivery to City of Kingsport locations shall be without additional charge.
3. Failure to examine any drawings, specifications, and instructions will be a bidder's risk. If bidder is in doubt as to the true meaning of any part of the drawings, specifications and instructions or other documents, he should submit a written request for an interpretation to the Procurement Manager. An interpretation of the documents will be made only by addendum issued by the Procurement Manager to each firm to whom an invitation was forwarded. The City will not be responsible for explanation or interpretations of bid documents except as issued in accordance herewith.
4. Where a brand or trade name appears in the specifications, it is understood that the brand or trade name referred to, or its approved equivalent, shall be furnished. If no mention is made of any exceptions, it is assumed that he is bidding on the article mentioned and not an approved equivalent.
5. The bidder is requested to attach brochure-type information on the supplies furnished. All guaranteed and warranties should be clearly stated.
6. Taxes. The City is exempted from Federal excise taxes and state and local sales taxes and bidders must quote prices which do not include such taxes. An exemption certificate will be furnished upon request.
7. Bids and modifications or corrections thereof received after the closing time specified will not be considered. The City is not responsible for delays in delivery by mail, courier, etc.
8. Any exceptions to these terms and conditions or deviations from written specifications will be shown in writing and attached to the bid form.
9. Any alteration, erasure, addition to or omission of requested information, change of the specifications, or bidding schedule, is made at the risk of the bidder and may result in the rejection of the bid, unless such changes are authorized by the specifications.
10. In the event cash discounts are offered by the bidder, the discount date shall begin with the date of the invoice or the date of receipt of all material covered by the order/contract, whichever is the later date.
11. Charges for boxing or cartage will not be allowed unless previously agreed upon.
12. Default in promised delivery and failure to comply with specifications authorizes the City to purchase supplies elsewhere and charge the difference to defaulting Vendor.
13. Bidder agrees to defend and save City of Kingsport from and against all demands, claims, suits, costs, expenses, damages and judgments based upon infringement of any patents relating to goods specified in this order or the ordinary use or operation of such goods by City or use or operation of such goods in accordance with bidders direction.
14. In case of error or discrepancy in the mathematics of the bid price, the unit prices shall prevail.
15. By submission of a signed bid, the bidder certifies total compliance with Title VI and Title VII of the Civil Rights Act of 1964, as amended, and all regulations promulgated thereunder.
16. Contracts and purchases will be made or entered into with the lowest, responsible, compliant bidder meeting specifications for the particular grade or class of material, work or service desired in the best interest and advantage to the City of Kingsport. Responsible bidder is defined as a bidder whose reputation, past performance, and business and financial capabilities are such that he would be judged by the appropriate City authority to be capable of satisfying the City's needs for a specific contract or purchase order.
17. The City reserves the right to determine the low bidder either on the basis of the individual items or on the basis of all items included in its INVITATION TO BID, unless otherwise expressly provided in the INVITATION TO BID. The City reserves the right to accept any item or group of items of any kind and to modify or cancel in whole or in part, its INVITATION TO BID.
18. All contracts or purchase orders issued for this award will be governed by the laws of the State of Tennessee.
19. The City, in accordance with its governing directives, reserves the right to reject any and all bids, to waive any informality or irregularities in bids and unless otherwise specified by the bidder, to accept any item.
20. The contract will be awarded for a period of one (1) year with a renewal option on an annual basis in one (1) year increments providing all terms, conditions and cost are acceptable to both parties. The City reserves the right to rebid at the end of any contract period.
21. **CONFLICT OF INTEREST:**
 - a) No Board Member or officer of the City of Kingsport or other person whose duty it is to vote for, let out, overlook or in any manner superintend any of the work for the City of Kingsport has a direct interest in the award of the vendor providing goods or services.

- b) No employee, officer or agent of the grantee or sub-grantee will participate in selection, or in the award or administration of an award supported by Federal funds if a conflict of interest, real or apparent, would be involved. Such a conflict would arise when the employee, officer or agent, any member of their immediate family, his or her partner, or an organization, which employs, or is about to employ, any of the above, has a financial or other interest in the firm selected for award.
 - c) The grantee's or sub-grantees officers, employees or agents will neither solicit nor accept gratuities, favors or anything of monetary value from vendors, potential vendors, or parties to sub-agreements.
 - d) By submission of this bid, the vendor is certifying that no conflicts of interest exist.
22. DRUG FREE WORKPLACE REQUIREMENTS:
- a) Private employers with five or more employees desiring to contract for construction services attest that they have a drug free workplace program in effect in accordance with TCA 50-9-112.
23. ELIGIBILITY:
- a) The vendor is eligible for employment on public contracts because no convictions or guilty pleas or pleas of nolo contendere to violations of the Sherman Anti-Trust Act, mail fraud or state criminal violations with an award from the State of Tennessee or any political subdivision thereof have occurred.
24. GENERAL:
- a) Vendor fully understands the preparation and contents of the attached offer and of all pertinent circumstances respecting such offer.
 - b) Such offer is genuine and is not a collusive or sham offer.
25. IRAN DIVESTMENT ACT:
- a) Concerning the Iran Divestment Act (TCA 12-12-101 et seq.), by submission of this bid/quote/proposal, each vendor and each person signing on behalf of any vendor certifies, and in the case of a joint bid/quote/proposal, each party thereto certifies as to its own organization, under penalty of perjury, that to the best of its knowledge and belief that each vendor is not on the list created pursuant to § 12-12-106.
26. NON-COLLUSION:
- a) Neither the said vendor nor any of its officers, partners, owners, agents, representatives, employees or parties interest, including this affiant, has in any way colluded, conspired, connived or agreed, directly or indirectly, with any other responder, firm, or person to submit a collusive or sham offer in connection with the award or agreement for which the attached offer has been submitted or to refrain from making an offer in connection with such award or agreement, or collusion or communication or conference with any other firm, or, to fix any overhead, profit, or cost element of the offer price or the offer price of any other firm, or to secure through any collusion, conspiracy, connivance, or unlawful agreement any advantage against the City of Kingsport or any person interested in the proposed award or agreement.
 - b) The price or prices quoted in the attached offer are fair, proper and not tainted by any collusion, conspiracy, connivance, or unlawful agreement on the part of the firm or any of its agents, representatives, owners, employees, or parties in interest, including this affiant.
27. BACKGROUND CHECK REQUIREMENT FOR SCHOOL SYSTEM SUPPLIERS:
- a) In submitting this bid/quote/proposal, you are certifying that you are aware of the requirements imposed by TCA § 49-5-413 (d) to conduct criminal background checks through the Tennessee Bureau of Investigation and the Federal Bureau of Investigation on yourself and any of your employees who may come in direct contact with students or who may come on or about school property anytime students are present. You are further certifying that at no time will you ever permit any individual who has committed a sexual offense or who is a registered sex offender to come in direct contact with children or to come on or about school property while students are present.

GENERAL PROVISIONS

1. The unit and associated equipment shall be furnished complete and in readiness for use.
2. Special Awarding Criteria. While the purpose of the bid document is to indicate certain minimum requirements, its use is not intended to relieve the City of all responsibility in making a selection which is the most suitable for the City's service.

Although proposals may be received based on the minimum requirements indicated, it is not intended that this alone shall limit the award but other factors will be considered, including the experience of the City and others.
3. Unless the capabilities of the equipment, which the Vendor bids, is known to the City, bidder agrees to provide a model within reasonable distance of the City of Kingsport, for evaluation purposes at no expense to the City of Kingsport.
4. Trade-in. Vendors are requested to consider a trade-in allowance for the following: City Vehicle # 1914 – 2009 Braun Paratransit Van, 2370 – 2017 Mobility Trans High Top Van, & 2371 – 2017 Mobility Trans High Top Van. Vendor is to contact Steve Hightower, Fleet Manager (423-224-2434) to arrange an appointment to inspect this vehicle. The City reserves the right to accept or reject any trade-in allowance.
5. OPTIONAL EQUIPMENT. Optional Equipment selection will be at the discretion of the City.
6. Specifications. SEE: Vehicle Specifications – 17 (seventeen) pages.
7. Bidder is requested to fill out the Bid Form and attach a completed copy of the specifications (Pages 1-61) to the Bid Form.
8. Any additions, deletions, variations from attached specifications must be noted. Any items appearing in manufacturer's regular published specifications furnished by bidder are assumed to be included in the "Bidder's Proposal".
9. At time of delivery to the City of Kingsport, vehicle must meet or exceed all federal, state, and local health, safety, lighting and noise standards.
10. At time of delivery to the City of Kingsport, vehicle must meet or exceed all existing DOT regulations and US EPA emission standards that are applicable to this type vehicle.

PRE-DELIVERY INSPECTIONS OF VEHICLES FOR SPECIFICATION COMPLIANCE

The City of Kingsport or purchaser, reserves the right to have an inspector to conduct an on-site visit to the vendor's manufacturing plant for the purpose of inspecting the vehicles under a specific procurement. The inspector, with the cooperation of the vendor, shall have the right to inspect all materials and workmanship at any time during the manufacturing process and at a minimum upon the vehicle reaching 90% completion. The inspector shall also have the right to reject all materials and workmanship that do not conform with the specifications; provided, however, that the purchaser is under no duty to make such an inspection. If such aforementioned inspection(s) by purchaser is (are) made or is (are) not made, the vendor shall not be relieved of any obligations to furnish materials and workmanship strictly in accordance with specifications.

Pre-acceptance inspection for Deficiencies in Specifications

Delivery of the vehicle(s) by the vendor does not constitute acceptance by the City. The vehicle(s) will be considered "accepted" upon passing the pre-acceptance inspection and receiving notification from the City of accepting the vehicle(s).

After receiving the vehicle(s) The City of Kingsport shall perform the Post Delivery inspection and submit a "Letter of Deficiencies" to the Vendor that states and describe the areas to be found in noncompliance with the bid specifications, incompleteness, or any defective or damaged parts. The Vendor has up to ten (10) calendar days after receiving this letter to comply with all areas addressed. A vehicle may be rejected if any items are missing, defective, altered, incorrect, or incomplete after the allotted time has passed. In the event a vehicle(s) is delivered incomplete or contains any defective or damaged parts, the said parts will be removed and replaced with new parts furnished and installed by the Vendor at no cost to the City. If there is work involved, warranty or otherwise, to repair or place the vehicle(s) in proper complete condition, such repairs will be made by an approved firm in accordance to the warranty provisions of the contract.

Acceptance of the vehicles shall not release the Vendor from liability for faulty workmanship or materials.

Supplemental Terms and Conditions

This Bid will include an option to allow the City of Kingsport / Kingsport Area Transit Service the right to purchase up to 2 additional vehicles. The City's use of this option will be dependent upon the price quoted by the offeror and the availability of Federal and local funding. The City may not exercise the option if the awarded bidder is either late in delivering the vehicles, and/or maintenance manuals and/or fails to provide adequate field service and support, and/or the quality of the vehicles is poor. The City may exercise this option clause from thirty (30) days after award of the Bid to two (2) years after the award of the Bid in the original base order.

Options for the purchase of up to 2 additional vehicles as specified in this bid are retained as a propriety right of the City. The City retains the propriety right to exercise the Option to Purchase the balance of said optioned vehicles or may assign said right to purchase any or all of the optioned vehicles to any governmental entity within the State of Tennessee for the same terms and conditions which are set forth in the proposal document incorporated herein. Authority for joint purchasing is granted by the Tennessee Code Annotated, title 12, chapter 3, part 10. In the event the City should assign the option rights to any other governmental agency it shall first be necessary for the City, through its City Manager, to execute a letter evidencing the City's consent to said entity exercising said option. The City will inform the awarded bidder if an option vehicle is assigned to another government entity. An entity to whom an option vehicle is assigned will enter into an individual purchase agreement with the awarded bidder.



**HIGH TOP VAN
MEDIUM DUTY - GASOLINE POWERED
EIGHT PASSENGER - TWO WHEEL CHAIR POSITIONS**

The unit(s) to be furnished under this proposal shall be a forward engine, gasoline powered, eight passenger, two wheel chair positions, single rear wheeled, lift equipped transit style high top passenger van, and shall be capable of transporting ambulatory as well as wheelchair bound patrons. This unit(s) shall be suitable for use as public transportation in a municipal transit service operation.

Any addition, deletion, or variation from the following specifications *shall be so stated* in the space provided. These specifications are to be construed as minimum. However, *any and all exceptions* will be weighed against the needs, experiences, and resources of the *City of Kingsport*. This unit as delivered shall conform to standards for a vehicle of this type as outlined by the American Disabilities Act and Federal Motor Vehicle Safety Standards. These specifications also require the bidder to furnish descriptive literature, complete specifications, and all other necessary technical data on the equipment as proposed by the perspective bidder. Failure on the part of the bidder to properly indicate compliance or supply requested information shall deem the bidder as non-responsive.

SPECIFICATIONS	Bid der Complies	YES	NO
1.0/ - GENERAL SPECIFICATIONS:			
1. Latest, current production model (2021 or later), eight passenger, two wheel chair position, forward engine, commercially manufactured, single rear wheeled, high top passenger van and equipped with wheel chair lift/ramp and wheel chair restraint systems, new and unused, with all standard equipment as offered by the manufacturer.			
2. All parts, accessories, equipment, and safety features considered "standard" by the manufacturer; whether specified herein or not, shall be considered as required.			
3. Vehicles and equipment awarded shall be built and delivered complete and ready for use in full compliance with federal, ADA, state, and local requirements and regulations.			
4. This unit, wheelchair lift, and all other related equipment incorporated into this unit shall be designed, built, manufactured, and constructed in accordance with all applicable safety codes, design standards, and manufacturing standards as outlined by SAE, ANSI, AWSI, and FMVSS and related organizations.			
5. This unit shall embody the highest quality materials and workmanship available.			
6. Providers must be a Manufacturer's Quality Vehicle Modifier (QVM) and certified from the vehicle manufacturer.			
7. Providers must supply in writing testing certification and documentation to meet the requirements as specified.			
8. This unit shall be designed and tested for operating for a minimum of four (4) years of service and/or 100,000 miles.			
EXCEPTIONS:			
2.0 - G.V.W.R.: The G.V.W.R. shall be a minimum of 9,500 pounds.			
EXCEPTIONS:			
3.0/ - WHEELBASE AND GENERAL DIMENSIONS:			
1. The wheelbase shall be a minimum of 148" inches.			
2. The overall exterior width shall be a minimum of 96" inches.			
3. The overall maximum height shall not exceed 107" inches.			
4. The interior floor to ceiling height shall be a minimum of 77".			
5. The passenger entryway door step height from the ground (no load) shall be no greater than 11" inches but no less than 8".			
6. Overall length shall not exceed 240" inches.			
7. These dimensions apply to the completed van.			
EXCEPTIONS:			

SPECIFICATIONS	Bid der Complies	YES	NO
<p>4.0/ - ENGINE:</p> <ol style="list-style-type: none"> The engine shall be an electronic 3.7 liter, V6 cylinder gasoline engine developing a minimum of 275 horsepower @ 260 lb.-ft. of torque and include OEM gaseous prep package. Engine noise levels shall not exceed 82dba under any circumstances. Engine compartment shall have manufacturer's standard noise insulation. Engine shall be supplied with a manually switched (on/off) OEM high idle system within easy reach of the operator. 			
EXCEPTIONS:			
<p>5.0/ - TRANSMISSION:</p> <ol style="list-style-type: none"> A six (6) speed heavy duty automatic w/overdrive transmission shall be provided. The transmission shall be equipped with a heavy duty auxiliary transmission air to oil cooler. The transmission shift lever shall be interlocked with the starting motor to prevent the engagement of the starter in any gear position other than neutral or park. Reverse activated solid state back-up alarm and back-up camera shall be provided. 			
EXCEPTIONS:			
<p>6.0/ - TOP SPEED: Top speed capability of this unit shall be a minimum of 75 MPH on a straight level road with all accessories operating.</p>			
EXCEPTIONS:			
<p>7.0 /- COOLING SYSTEM:</p> <ol style="list-style-type: none"> The manufacturer's heaviest duty cooling package with coolant recovery system shall be provided. (Engine temperature shall not exceed 195° Fahrenheit degrees with "permanent" type antifreeze.) Gates "Blue Stripe", or equivalent, cooling hoses shall be provided using the appropriate type constant torque hose clamps. The radiator fan shall be heavy duty and temperature controlled. Manufacturer's heavy duty radiator shall be provided. Cooling system shall be protected to a minimum of -20° Fahrenheit. 			
EXCEPTIONS:			
<p>8.0/ - WHEELS AND TIRES:</p> <ol style="list-style-type: none"> Four (4) radial, highway tread type tires (235/65R16, Load Range "E", minimum) shall be provided. Wheels shall be one piece, heaviest duty available, ventilated steel recommended for the G.V.W.R. and tires specified. All wheels shall be completely interchangeable. Manufacturer's standard wheel covers shall be provided. A "mounted on rim" spare tire and wheel shall be provided and match the brand and size on the unit (Making a total of 5 tires and wheels for the unit). An OEM jack shall be provided and mounted at the back corner of the van. The wheel wrench and appropriate tools shall be located inside the front passenger step well compartment. 			
EXCEPTIONS:			

SPECIFICATIONS	Bid der Complies	YES	NO
9.0/ - SUSPENSION AND AXLES: 1. The vehicle shall be built on a heavy duty van type chassis. 2. The manufacturer's heavy duty spring type suspension shall be provided. 3. All shock absorbers, springs, wheel bearings, hubs, and spindles shall be appropriately rated for the G.V.W.R. specified. 4. The front axle and suspension shall be rated at 4,100 pounds, minimum. 5. The rear axle and suspension shall be rated at 5,700 pounds, minimum. 6. OEM or aftermarket front and rear stabilizer bars meeting the GVWR requirements shall be provided. 7. All parts and elements of the suspension, steering, and drive systems that require scheduled lubrication shall be provided with OEM grease fittings. 8. A minimum of three (3) drive shaft loop(s) shall be provided.			
EXCEPTIONS:			
10.0/ - REAR AXLE RATIO: Rear axle ratio shall be a minimum of 3.31:1.			
EXCEPTIONS:			
11.0/ - STEERING: 1. Full power steering with tilt and telescoping wheel option shall be provided. 2. The steering mechanism shall be constructed so as to make the wheel free from road shock and vibration. 3. Steering from full left to full right turn shall be accomplished in no more than five (5) complete turns of the steering wheel. 4. The steering mechanism shall be self-centering, requiring little or no effort to bring the vehicle back to the straight-ahead position after turning. 5. All steering linkage wear points, including tie rod ends, shall be fitted with lubrication fittings and replaceable bushings and/or inserts if available.			
EXCEPTIONS:			
12.0/ - TURNING RADIUS: 1. Unit shall have a wall to wall turning diameter of no more than 50.1' feet (maximum). 2. Unit shall have a turning diameter not to exceed 48.6' feet maximum. 3. Bidder shall supply curb to curb and wall to wall turning radius with proposal.			
EXCEPTIONS:			
13.0/ - EXHAUST: 1. The unit shall be equipped with an exhaust system which meets and/or exceeds United States Government noise level and exhaust emission (smoke and noxious gases) requirements. 2. There shall be a <u>heat shield provided</u> between the exhaust pipe and fuel tank if the exhaust passes within eight (8") inches of the fuel tank. 3. The exhaust system shall terminate out of the left rear (drivers side) of the unit(s). 4. The exhaust system routing shall not prohibit the removal of the under frame mounted spare tire from the spare tire carriage assembly. 5. The exhaust tail pipe shall be clear of the fuel fill position. 6. <i>Alum inize d or Stainle ss Steel</i> exhaust components shall be provided. 7. A 45° turn down shall be provided on the exhaust tip.			
EXCEPTIONS:			
14.0/ - BRAKES: 1. Manufacturer's heavy duty, extreme service, four wheel ABS equipped, self adjusting, power assist hydraulic brake system shall be provided. 2. "Disc Front/Drum Rear" or "Four Wheel Disc Rotor" systems are acceptable. 3. The braking system shall conform to all Federal Motor Vehicle Safety Standards and shall exceed requirements for the design of the G.V.W.R. specified. 4. The braking system shall be free of objectionable noise or squeal when applied.			
EXCEPTIONS:			

SPECIFICATIONS	Bid der Complies	YES	NO
<p>15.0/ INSTRUMENT PANEL, DASH, AND OTHER CONTROLS:</p> <ol style="list-style-type: none"> 1. The dash shall coordinate with the interior trim color. 2. The glove box shall be provided with an OEM light and lock. 3. The Instrument Panel and Dash shall be equipped with the following OEM instruments, gauges, and control (Lights in lieu of gauges are not acceptable except as noted): <ol style="list-style-type: none"> a. Speedometer with odometer and trip odometer b. Oil pressure gauge c. Voltmeter d. Engine coolant temperature gauge e. Fuel gauge f. Upper beam head lamp indicator g. Dual-note horn h. Directional signals (light) i. Parking brake on (light) j. Headlight switch k. Inside hood release l. Heater, defroster, and air conditioning controls m. Standard OEM AM/FM radio w/digital clock & speakers n. Variable Speed, with Intermittent Feature, Windshield Wipers and Washers o. Emergency Flashers p. Cruise Control 4. All controls and switches shall be clearly labeled and within easy reach of the driver. 5. No overhead switches or controls shall be permitted except for the passenger door control switch. 6. A double momentary rocker style passenger door switch shall be provided. 7. The passenger door switch shall be oriented left to right so that the passenger door opens when the switch is pushed to the right (curbside) of the vehicle and the door closes when the switch is pushed towards the left side (driver side) of the vehicle. 8. OEM driver's sun visor to be provided. 9. An optional coat hook and grab strap shall be provided in driver area. 10. OEM driver's side air bag to be provided in steering wheel. 11. OEM front passenger air bag to be provided. 			
<p>EXCEPTIONS:</p>			

SPECIFICATIONS	Bid der Complies	YES	NO
<p>16.0/ - ELECTRICAL SYSTEM:</p> <ol style="list-style-type: none"> 1. The unit shall be equipped with a 12 volt heavy duty electrical system. 2. An OEM dual battery system shall be provided with a minimum of 1,400 cca., 12 volt, maintenance free type with 120 minute reserve power and appropriate wiring or cables to carry the electrical load. 3. The alternator shall be rated at 200 AMP, minimum. 4. All other electrical components shall be selected and integrated to function in an environment characterized by low engine (alternator) speeds and high amperage demands and shall be so installed as to meet with the intent of this specification section. 5. All accessories and electrical equipment with the exception of the head lights, tail lights, parking lights, emergency flashers, and lift shall be wired through the vehicle ignition switch so as to be operative only with the switch in the "on" or accessory position. 6. All wiring and terminals shall meet or exceed current Federal and State vehicle requirements and must be amply sized for both mechanical strength and current carrying capability. 7. Wiring shall be enclosed in non-metallic loom meeting current S.A.E. standard J562a and be adequately supported and routed for protection from heat, moisture, solvents, corrosion, road debris, abrasion, and tension and shall meet published OEM upfitter approved guidelines. 8. Wiring shall be of significant strength to permit positioning, as well as replacement of terminals twice without excessive tension. 9. Protective grommets shall be provided at points where wiring penetrates metal or other materials. 10. Power wires to the lift/ramp shall be securely clamped and protected. 11. Grounding of components shall be through polarized, shielded terminals wired to main structural ground points. 12. Grounding through hinged doors or covers is not acceptable. 13. Ground points shall be bolts to main structure free of paint, oil, or rust and they shall be coated with silicone grease after fastening. 14. All electrical components which may require servicing or replacement shall be readily accessible through access panels or covers. 15. A complete and thorough wiring diagram(s) shall be provided with each unit. 16. All wiring shall be TXL polyethylene insulated low smoke sufficient gauge copper strand, or better, for the circuit using the wires. 17. Wiring shall be color coded and numbered for identification. 18. All wiring shall be run inside the body in a protected area. 19. Wiring shall not be within ANY airbag deployment zone. 20. Wiring shall be enclosed in a non-metallic loom and secured in place. 21. Any penetration of wiring through metal points or other materials shall have protective rubber grommets installed in such opening. 22. All circuit breakers and/or fuses provided shall be enclosed in a electrical panel that shall be easily accessible. 23. A separate and fused optional electrical control panel for add on components shall be provided and easily accessible. 24. The electrical control panel shall provide power outlets for the addition of a two way radio system, tablet charging, and security camera/DVR power. 25. NOTE: Lock wire connectors or scotch locks shall not be allowed on any wiring hookup or connection. 26. All terminal connections shall be stake on type, soldered, or better, with heat shrink tubing insulating the wiring and terminal. 27. Power wire provided for the wheel chair lift/ramp shall be in a loom fully secured with a manual reset type circuit breaker. 28. Vendor shall provided an optional shut down system that shall turn the engine off if the engine has been idling for a set period of time. 29. The engine idle limiter shall be designed to help save fuel and protect the environment by limiting the time that an engine is permitted to remain idling when the vehicle is parked. 30. The unit shall come with a factory pre-set 30 minute delay. 31. The unit shall have provisions for timing adjustments if adjustments are needed. 32. The idle limiter shall have a countdown sequence that will be initiated when the parking brake (or other switch that is ground when engaged) is set OR command signal is received from "Park" position. If the signal is removed before the time period expires the unit is reset and the engine shall not shut down. The unit shall be connected to the Run, Fuel Pump, or Coil circuit on the engine or the ECM. 33. Manufacturer's up-fitters "in dash mounted" switch package shall be provided and contain a minimum of two (2) fused, thirty (30) amp, and two (2) fused, ten (10) amp, (total 4 switches) illuminated rocker style switches. 34. An OEM chassis factory mounted (original location) ALDL connector shall be provided regardless of interface connections. 			
<p>EXCEPTIONS:</p>			

SPECIFICATIONS	Bidder Complies	YES	NO
<p>17.0/ - CLIMATE CONTROL/ HEATING/ COOLING:</p> <ol style="list-style-type: none"> 1. Front heater and defroster shall be OEM with the maximum BTU rating available. 2. Front, high capacity, air conditioning shall be provided. 3. An OEM in-dash unit shall be supplied with the maximum BTU rating available. 4. The dash unit shall be separately controlled from the auxiliary rear air conditioning system that shall be provided. 5. Both front and rear A/C units shall be serviceable at any OEM dealer. 6. The passenger area air conditioning and heat shall be controlled separately from the front A/C and heat. 			
<p>EXCEPTIONS:</p>			
<p>18.0/ - INTERIOR:</p> <ol style="list-style-type: none"> 1. The unit shall be insulated with the manufacturer's <i>heaviest duty factory installed insulation package</i> on the walls, if available. 2. All insulation shall be flame retardant and non-toxic. 3. Polyurethane foam is acceptable as an insulation material. 4. The engine compartment shall be insulated from the passenger compartment with OEM manufacturer's optional heavy duty insulation so as to minimize interior noise, heat, and fumes. 5. Interior finish shall be completed in a highly professional manner and exceed OEM requirements with all components, panels or other provided items correctly installed. 6. All upholstery panels shall have adequately installed retainers to prevent items from having gaps or coming loose during the useful life of the unit(s). 7. Interior color of unit(s) shall be manufacturer's and shall 8. be chosen at award of bid. 9. Bidder shall supply a color selection chart as part of their bid submission. 10. All sharp edges, sharp corners, and/or protrusions shall be eliminated for safety reasons. 11. Vehicles shall meet all applicable requirements of the ADA as set forth in 49 CFR 37 and 38, issued 9/16/91; and 49 CFR 571; all applicable FMVSS requirements, including but not limited to 208, 302, 403 and 404 with respect to the vehicle. 12. Interior paneling must be OEM from the vehicle manufacturer. 13. All interior panels, materials, and treatments shall be subject to FMVSS 302 and all other applicable FMVSS requirements. 14. A dual purpose manually operated ventilation/emergency exit shall be installed in the raised roof of the vehicle at approximately the center of the passenger compartment. 15. The hatch shall be 22" x 22" minimum and shall be installed so that when it is open and the vehicle is in motion, fresh air will circulate in the vehicle. 			
<p>EXCEPTIONS:</p>			

SPECIFICATIONS	Bid der Complies	YES	NO
<p>19.0/ - SEATING:</p> <ol style="list-style-type: none"> 1. Seating shall be provided for a minimum of eight (8) passengers, a driver and two (2) wheel chair positions. 2. The driver's seat shall be a 10 way, ebony cloth covered, power heated, OEM deluxe high back, fully padded, contoured bucket type of heavy-duty construction with arm rest and lumbar support and shall include factory seat belt extensions. (Ford Code 21R) 3. The RF OEM passenger seat shall be delivered .loose because the passenger seat area shall be a cargo area that shall match the current fleet 4. The driver's seat shall be easily adjusted forward and backward without the use of tools and must recline to a minimum of 110° degrees with the seat in the fully rearward position.. 5. An OEM uni-belt restraint system is required. 6. Vinyl upholstery color shall be chosen at award of bid. 7. All left side passenger seating shall be three way fold up style, similar in design and performance characteristics to the Freedman "Go-ES Space Saver Fold Down" with arm rests. 8. A minimum of two (2) curbside flip fold seats shall be provided. 9. The curbside seats shall be Freedman single foldaway Model 44001 Go-ES seats. 10. Freedman Go-ES seating shall be provided shall be provided with the Freedman TDSS tie down storage system for "L" track fittings installed under each bench seat. 11. All seating must be in compliance with the new requirements of FMVSS 208 and all other applicable FMVSS requirements. 12. Bench seating shall be provided in single or double passenger sizes depending on seating configurations shown in the provided seating diagram. 13. Forward facing foldaway seats (single or double) shall be provided over wheelchair stations. 14. All seats shall be heavy-duty construction with 1" 16 gauge reinforced tubular steel frames. 15. All metal surfaces shall be chemically cleaned, iron phosphate, painted and baked to provide rugged, long lasting, rust resistant surfaces. 16. All seat backs should be a minimum of 16 gauge 1"x16" steel straps, welded to the seat frame. 17. All seat bottoms shall use a flexolator suspension system for even support. 18. Upholstery material shall be 36oz./sq yd, minimum, transit vinyl. 19. Seats shall be color-keyed to the vehicle's interior panels and exterior color based on awarded color choice. 20. Foam padding shall be high density (4.5 pcf) non-deformable foam with load bearing values in excess of 45ILD. 21. Seating arrangements shall be equally spaced between rows and mounted as close to the wall as possible to provide adequate isle space for wheel chairs. 22. Foldaway seats shall meet the above seat requirements. 23. The foldaway seats shall not exceed 15" width when they are in the stored position. 24. All seating shall meet or exceed all applicable FMVSS requirements, including, but not limited to FMVSS 302, 207, and 208 25. Each passenger position shall be provided with a three (3) point seat belt system with an under seat mounted retractor restraint lap belt to hold passengers in a secured seated position during normal operations. 26. Seat belt extenders shall be provided for all seating locations, to include the drivers seat, and match in mechanics and color to the seat belt system provided for the provided seating. 27. At a minimum, the length of each primary passenger belt shall be as long as allowed by Federal Motor Vehicle Safety Standards and design requirements/limitations. 28. Seat belts shall be designed and installed in accordance with applicable Federal Motor Vehicle Safety Standards. 29. Refer to <u>Seating Diagram</u> Figure 1 , page 16 , for seating/ wheelchair position placement requirements. 			

EXCEPTIONS:

<p>20.0/ - FLOOR AND FLOOR COVERING:</p> <ol style="list-style-type: none"> 1. Sub-flooring utilized shall be a minimum of 5/8" thick securely fastened to the understructure. 2. The floor covering shall be wall-to-wall, one piece, fire resistant, slip resistant, transit quality flooring securely bonded to the plywood floor with waterproof type adhesive. 3. All edges in the floor covering shall be properly sealed and shall have coving sticks installed to provide sharp, even corners/edges to the one piece floor covering. 4. There shall be no bubbles or blisters in the floor covering. 5. Altro "Transflor Chroma"/ Color: Strada flooring shall be provided and a minimum of 2.7 mm thick, NO EXCEPTIONS. 6. A slip-resistant surface shall be provided in the step area of the driver, side and rear door entrances. 7. Black or clear silicone caulking shall be used at all points where moisture may enter the floor material. 8. Floor shall be free from metals and DEHP plasticizer 9. Floor edges should be covered with 1"x1" aluminum molding. 10. Heavy duty rubber or vinyl front driver and passenger floor mat shall be provided. 			
---	--	--	--

EXCEPTIONS:

SPECIFICATIONS	Bid der Complies	YES	NO
<p>21.0/ - STEPS AND STEP WELLS:</p> <ol style="list-style-type: none"> 1. An optional exterior mounted driver side running board style step shall be provided at the OEM left front door entry to allow easy operator entry to the vehicle. 2. The step shall extend a minimum of 25" in length and be mounted directly below the driver step well to allow ease of entry for driver. 3. A step shall be provided for the transit style passenger entry way door and shall be a 9" rise x 9" run to protect passengers from a tripping hazard. 4. The transit passenger entry way steps shall be covered with a non slip surface and shall be highlighted with a YELLOW nosing with the wording "WATCH YOUR STEP" on each step provided. 5. Refer to "Section 3" for passenger entry step dimensions. 			
EXCEPTIONS:			
<p>22.0/ - DOORS:</p> <ol style="list-style-type: none"> 1. The Transit Passenger Entrance shall be a "Transit Style" dual leaf door with integrated hand rails and door sweeps. 2. The opening to the entrance shall be a minimum of 36" in width and 78" in height. 3. The door frame shall be made from 11 gauge steel utilizing an ANM door or equivalent. 4. The transit passenger door shall have "walk-in" headroom, as measured from the top of the front step to the entrance header, and padded to prevent passenger head injuries. 5. The transit passenger door shall be controlled by a manually operated, momentary switch located overhead and to the right of the drivers position and clustered near the "dome/map lights" module. 6. The transit passenger door have a securely mounted, but easily removable, access panel to repair and maintain the passenger door operating mechanisms and wiring. 7. OEM front doors shall be provided on the unit(s) and shall be retained to include OEM power window and door lock options. 8. A wheelchair lift door shall be provided and located on the rear of the unit(s) and mounted with heavy duty hinges. 9. The wheel chair door(s) shall provide an appropriate width as measured when lift is in full raised and usable position. 10. The lift door shall have a clear opening width adequate for ease of operation of the wheelchair lift being provided with this vehicle. 11. The lift door shall be equipped with a metal safety device to hold door securely in full open position when lift is in operation. 12. Padding shall be installed inside of the unit(s) over wheelchair lift door to prevent head injuries. 13. Locks and keys shall be supplied for all doors including the switched operation of the electrically controlled transit passenger door from outside the vehicle. 14. A minimum of four (4) sets of keys with FOBS shall be provided with the unit(s) 15. All doors shall be properly sealed to prevent entry of air drafts and water into vehicle interior, including spray from commercial vehicle wash equipment and driven rain. 16. Materials used for weather seals shall be designed to withstand varying temperature extremes, road splash, salt and other elements. 			
EXCEPTIONS:			
<p>23.0/ - WINDSHIELD AND WINDOWS:</p> <ol style="list-style-type: none"> 1. The windshield shall be tinted and laminated safety glass. 2. The vehicle chassis will have dark tinted glass in the passenger area. 3. One hinged emergency escape window shall be provided on the left side of the van. 4. Emergency windows shall be clearly labeled and operating instructions shall be clearly visible. 5. All windows shall be designed and installed in compliance with FMVSS 217. 6. All glazing and windows shall meet all applicable Federal and State Motor Vehicle Safety Standards. 			
EXCEPTIONS:			

SPECIFICATIONS	Bid der Complies	YES	NO
<p>24.0/ - INTERIOR LIGHTING:</p> <ol style="list-style-type: none"> 1. All interior lighting shall be LED. 2. Interior shall be illuminated so as to provide a minimum of 151 lumens of illumination as measured at thirty six (36") inches above the floor. 3. A minimum of six (6) LED overhead interior lights, operator controlled, shall be provided. 4. The basic interior van lighting configuration shall include the following: <ol style="list-style-type: none"> a. A driver's compartment dome light; b. Instrument panel lights; control panel back lighting; c. A minimum of six (6) LED lights for passenger area illumination. d. All step well lighting shall adequately illuminate the step well area with the door open; (wired to automatically activate when the passenger door is opened). 5. Lighting shall be designed and located so that no glare is reflected into the driver's eyes or line of vision from the switch control panel or other areas that are illuminated while the vehicle is in motion. 6. A driver controlled override shall be provided to allow operation of all interior lighting when the transit passenger door is closed and allow the driver to turn the lights on or off regardless of door position. 7. Wheelchair lift light(s) shall be provided to illuminate both the lift device and street surface. <ol style="list-style-type: none"> a. The light(s) shall automatically operate when the lift door is opened. 			
EXCEPTIONS:			
<p>25.0/ - EXTERIOR LIGHTING:</p> <ol style="list-style-type: none"> 1. All exterior lighting shall be LED and must meet State and Federal D.O.T. and FMVSS Requirements and Standards. 2. Directional signals shall meet all Federal and Tennessee Motor Vehicle Safety Standards front and rear. 3. Hazard warning lights incorporating the directional signals shall be provided. 4. The flasher unit for the directional signals and emergency flashers shall be replaceable from inside the vehicle and shall be of solid state, plug-in design. 5. An illuminated rear license plate bracket shall be provided on the rear of the vehicle. 6. A light shall be provided to illuminate inside the passenger door step well to provide light to the passenger step when the transit door is open. 7. The light shall provide a minimum of a 1' candle illumination. 8. Vendor shall supply four (4) alternating flashing LED amber warning cap riser lights which shall come on automatically when the wheel chair lift door is opened and shall be no less than a 5"x1" inch bar style light with a minimum of six (6) internal LED's. 9. The cap lights shall be programmable and synchronizable. 10. Two (2) of the cap lights shall be rearward mounted in the riser cap above the wheel chair lift door and two (2) lights shall be rearward mounted on the left and right sides of the riser cap. 11. If rearward facing lighting cannot be placed in the riser cap, provisions shall be provided for two (2) rearward facing flashing lights to be provided whether the rear doors are open or closed. 12. These four (4) mounted cap riser lights shall be angled downward for optimal oncoming traffic visibility. 13. Warning light operations shall be overridden on or off by utilizing one of the switches in the manufacturer's up-fitter's switch package to be provided. 			
EXCEPTIONS:			
<p>26.0/ - PAINT AND UNDERCOATING:</p> <ol style="list-style-type: none"> 1. Exterior of van shall be painted manufacturer's standard white color. 2. The entire underside of the vehicle body, including the underside of fenders, shall be coated with fire resistant asphalt base rubber base, in order to seal, deaden sound, insulate and prevent oxidation. 3. The entire body frame under structure of the unit(s) shall be fully under coated. 4. Under coating shall be applied to all points where dissimilar metals are joined together. 5. The application of undercoating shall follow approved conversion guidelines in compliance with QVM program and not jeopardize the corrosion warranty from the chassis manufacturer. 			
EXCEPTIONS:			
<p>27.0/ - STANCHIONS AND GRAB RAILS:</p> <ol style="list-style-type: none"> 1. In no circumstance shall any protrusions of any kind be allowed on any interior surface, which includes any retaining hardware. 2. Interior body mounted grab rails shall be provided on both sides of the transit passenger entry door. 			
EXCEPTIONS:			

SPECIFICATIONS	Bid der Complies	YES	NO
28.0/ - MIRRORS: 1. Unit shall be equipped left and right hand side mounted rear view mirrors. 2. The vehicle will have OEM heated and remote controlled exterior mirrors with convex option. 3. Remote mirror control shall be provided within easy reach of the operator.			
EXCEPTIONS:			
29.0/- WHEELCHAIR MOBILITY AID STATION(S): 1. Wheelchair/mobility aid stations(s) are the space inside the vehicle for transporting persons in wheelchair/mobility aid devices and are to be provided on vehicles having wheelchair/mobility aid lifts. 2. Each wheelchair/mobility aid device station shall consist of a usable floor area where a passenger in a wheelchair/mobility aid device may be positioned and where a wheelchair/mobility aid system shall be installed. 3. All wheelchair/mobility aid stations shall be designed to secure wheelchair/mobility aid devices in a forward facing position. 4. The stations shall not be any less than the minimum length of 48" required in accordance with ADA. 5. No wheelchair/mobility aid station(s) obstructions shall hinder a wheelchair/mobility aid device from being rolled into place. 6. Foldaway seats shall be mounted in a forward facing position. 7. All foldaway seats mounted over wheelchair/mobility aid stations area shall be Freedman "Go-ES" step foldaway seats with armrests. 8. Foldaway seats shall be color-keyed to the permanent passenger seats. 9. A minimum of one (1) wall-mounted, self-tensioning and auto-locking retractor system to secure a walker or stroller shall be provided and offer one-handed operation to the user. 10. The system shall be of the Q Straint brand, model number Q-3009. 11. The walker system shall be mounted per the City of Kingsport requirements.			
EXCEPTIONS:			
30.0/ - WHEELCHAIR LIFT: 1. Wheelchair lift shall be a fully automatic electric hydraulic Braun Century Wheelchair Lift or equivalent. 2. The lift shall be rated by the manufacture to lift a minimum of 800# pounds. 3. Lift dimensions shall be 34" wide by 51" long. 4. Lift and vehicle must meet all ADA requirements and FMVSS 403 and 404. 5. The lift shall have a manual back up system. 6. The wheelchair lift assembly shall be mounted in the interior rear of the vehicle. 7. Lift shall be fully automatic including platform operations. 8. All power units, operating joints, linkage and mounting points shall be certified by the manufacturer as being adequate for the load rating. 9. The lift shall be equipped with a manual over-ride system to permit lift to be raised or lowered in the event of a power failure or other emergency. 10. Controls must be sequentially interlocked to prevent folding of the lift platform before it is in the full raised position. 11. A hand held lift control shall be provided, with a minimum 5 feet of cord attached, so the lift may be operated from outside or inside the drivers side of the vehicle. 12. A provision shall be made for storing the lift controls inside of the left rear door of the unit(s) when they are not in use. 13. Lift control box shall be light weight and weather proof. 14. A passenger handrail shall be provided on both sides of the lift platform. 15. All pulleys, chains, cables, wires, hydraulic lines, etc. on both the lift and lift platform shall be fully enclosed. 16. Lift platform shall be a minimum of 30" inches clear usable width as measured from inside edge to inside edge of the platform. 17. A safety device shall be provided that secure the unit during transport.			
EXCEPTIONS:			

SPECIFICATIONS	Bid der Complies	YES	NO
<p>31.0/ - WHEELCHAIR SECUREMENT SYSTEM:</p> <ol style="list-style-type: none"> 1. The four point track/belt tie down shall be provided at each wheelchair/mobility aid device position as per L Track Diagram 2, Page 17 and WC-18 compliant. 2. Securement systems and their attachments to the vehicle, shall withstand a force in a forward longitudinal direction of 2,500 lbs. per a securement leg and a minimum of 5,000lbs. for each aid device. 3. Movement of an occupied wheelchair/mobility aid device shall be no more than 2" in any direction. 4. The system shall be composed of the following components: <ol style="list-style-type: none"> a. Four (4) separate belts and four (4) lengths of track with all necessary buckles mounted length wise (front to rear). b. Hardware fittings and other parts to make it a complete wheelchair/mobility aid device securement system. c. Q-Straint MAX retractable, knobless, one handed operation, tie down system. 5. The floor tracks for the wheelchair/mobility aid stations shall sit flush with the floor to ensure that no debris obstructs the securement for the wheelchair/mobility aid station. 6. Installation of the L-Track or any wheelchair/mobility aid securement system shall not cause damage to the fuel tank or any other vehicle component. 7. Each wheelchair/mobility aid station shall have a separate securement for each set of tie downs and the shoulder belt provided for the each system shall retract automatically to the wall. 8. The floor tracks for the wheelchair/mobility aid stations shall sit flush within the floor to ensure that no track obstructs the movement or securement of the wheelchair/mobility aid station. 9. Vendor shall certify that the wheelchair/mobility aid device securement system will meet all applicable Federal Motor Vehicle Safety Standards, and has been mounted in accordance with the OEM Chassis Manufacturer's and Restraint System Manufacturer's specifications. 10. Two spare sets of lap tie down belts shall be provided for each unit(s) and shipped with the unit(s). 11. An additional ten (10) Q-Straint webbing belt loops (#Q5-7680-6) shall be provided per unit. 12. A Freeman TDSS tie down storage system shall be provided under each bench seat to provided storage for the Q-Straint belting systems. 			

EXCEPTIONS:

<p>32.0/ - EXTERIOR CONSTRUCTION:</p> <ol style="list-style-type: none"> 1. All bidders should be aware that the City of Kingsport is seeking to purchase a heavy duty, unibody, raised top passenger van capable of operating a minimum of 25,000 miles per year for a period of four (4) years. 2. <i>The bidder shall provide City of Kingsport a complete set of photographs of the proposed van, design statement and supporting documentation of the bidder's claim that van will meet or exceed requirements.</i> 3. The raised roof shall be part of a unitized body constructed OEM vehicle. 4. Vehicles shall meet all applicable requirements of the American with Disabilities Act (ADA) as set forth in 49 CFR 37 and 38, issued 9/6/91; and 49 CFR 571, FMVSS 403 and 404, issued 12/27/02 with respect to the body structure. 5. Wheelhouses shall have sound deadening material to prevent road noise transmission to passenger compartment. 6. Rear absorbing type bumper shall be provided, silver in color, and project a minimum of 2" from body of the unit. 7. All nuts, bolts, fasteners, etc., used in body construction must be corrosion resistant and of North American manufacture. 8. Access panels shall be provided to service transmission, engine, radiator, battery and A/C components. 9. <u>Certified copy of FMVSS rollover protection test results</u> for this type of vehicle shall be submitted with the bid documents. 			
--	--	--	--

EXCEPTIONS:

SPECIFICATIONS	Bid der Complies	YES	NO
<p>33.0/ - MISCELLANEOUS:</p> <ol style="list-style-type: none"> 1. Unit shall be equipped with a 25 gallon (minimum) fuel tank. 2. Solid State visible and audible warning devices shall be installed to inform surrounding vehicle operators and pedestrians of reverse movement operation. 3. OEM provided dual tone horns, power windows, power door locks shall be provided. 4. Vehicle shall be equipped with rear of front tires and rear of rear tires mud flaps. 5. Emergency and Safety Equipment shall be a rechargeable 5 lbs fire extinguisher with an ABC rating, a minimum 16 unit first aid kit, and three folding reflective triangles with a storage container and shall be mounted as specified by the City of Kingsport. 6. Body fluids kit shall be provided and shall be securely mounted in an easily accessible location as specified by the City of Kingsport. 7. The right front passenger seat shall be supplied loose on delivery with the seating area to be a cargo storage area with the configuration matching the current fleet. 8. A minimum of four (4) sets of keys with Remote Control FOBS shall be provided with each unit. 9. Any labeling used to identify any up-fitted switches, valves, or other operating device will require an engraved label. Laminated labels will not be acceptable. 			
<p>EXCEPTIONS:</p>			
<p>34.0/ - AUDIO ELECTRONICS:</p> <ol style="list-style-type: none"> 1. An OEM <u>ONLY</u> AM/FM CD radio system with a minimum of six (6) speakers shall be provided. 			
<p>EXCEPTIONS:</p>			
<p>35.0/ - BATTERY CHARGING AND MAINTENANCE SYSTEM:</p> <ol style="list-style-type: none"> 1. Vendor shall provided a Dual Charge Brand “Pro Charge PS1 or PS2” battery charging and maintenance system. 2. The unit(s) shall be fully installed as per manufacturer’s directions and ready for full use on vehicle delivery and provide a charging bank per battery supplied. 3. The system shall be approved for Wet Cell and AGM batteries. 4. The unit shall be capable of producing a minimum of 15 amps per bank and a 15 amp bank per battery shall be supplied. 5. The unit shall be repairable, waterproof, and of weatherproof construction with fully automatic / multi stage charging capability and have a battery maintenance mode. 6. The charger shall have the ability to provide on-board diagnostic codes to determine battery condition as well as provide temperature compensated battery recharging. 7. The charger shall provide LED lights to indicate the state of charge. 8. The unit shall be reverse polarity protected. 9. A mounted metal, weather proof, three prong, 110V receptacle connection shall be provided for the battery charger/maintainer. 10. The connector shall be flush, body mounted behind the right front wheel. 11. The unit shall be in cab mounted and easily viewable by the operator or servicing technician as specified by the City of Kingsport. 			
<p>EXCEPTIONS:</p>			

SPECIFICATIONS	Bid der Complies	YES	NO
<p>36.0/ - VIDEO SYSTEM:</p> <ol style="list-style-type: none"> 1. Vendor shall supply a digital video system similar in design and performance characteristics to the REI HD1200-6-1TB 2. The system shall be of a unique compact rugged design to meet the demands of harsh mobile environments. 3. The mobile DVR system provided shall feature the latest technologies including Removable USB Hard Disk Drive Modules, Ethernet, and GPS. 4. Any camera's mounted to the interior head-liner surface shall be provided with a minimum of a 14 gauge sheet metal backing, or equivalent, behind the head-liner surface to retain the camera's in place. 5. The camera mounting locations shall be as per Diagram on Page 16. 6. The system provided shall have the following at a minimum: <ol style="list-style-type: none"> a. HD1200W-6-1TB - REI 12 CH DVR w/6 Cameras (2 additional Dome camera's shall be provided as spares for 8 camera's total to be provided) b. 1 TB Hard Drive (2 total required) c. 710609 12 CH Channel DVR, HD1200W d. 512002 16 FT Power Cable, BW-4, RX Series & HD Series DVRs e. 512168 25 FT Camera Cable (3 ct) f. 512167 15 FT Camera Cable (3 ct) g. 710675 CAM MB AHD WDR 170 HPOV 781- Dome Camera with Audio, 2.8mm, Front to Rear h. 710559 CAM, EXT AHD 85D RT RR/LT FT 778, Right - Facing Forward on Right Side of Unit. i. 710558 CAM, EXTERIOR, 2.8MM REAR/SIDE DOOR, Rear - Facing Rearward j. 710710 IP CAM with audio, MINIDOME AHD 115D HFOV 788- RF facing forward through the windshield k. 710675 CAM MB AHD WDR 170 HPOV 781 - Interior Left Side Mounted facing the Passenger Entrance l. 710675 CAM MB AHD WDR 170 HPOV 781 , Rear to Front m. 530076 Cable, USB 2.0 Type 'A' Male / Type 'A' Male / Type 'B' Male, 3 FT n. 512246 Exterior Camera Adapter Cable (2 ct) o. 710639 1 TB Hard Drive, Mobile DVRs (A quantity of two (2) 1 terabyte hard drives shall be provided per unit) p. 710214 SiRF3 GPS Antenna/Receiver Module, 16 FT q. 710335 Inertia Sensor, Accelerometer, 8G, HD Series Mobile DVRs r. 512209 Harness, DVR Vehicle Sensors 20' s. 511986 Bus-Watch Harness, Alarm/Panic, 20' t. 750363 Rear End Cap Kit, Rx001 and HD Series DVRs 			
EXCEPTIONS:			
<p>37.0/ - MANUALS:</p> <ol style="list-style-type: none"> 1. Two sets of owner/operator manuals, repair manuals, parts books, wiring diagrams, lubrication charts, and all other technical data for this unit(s), as equipped, shall be provided upon delivery. 2. The manuals provided with the unit(s) shall cover the unit(s) as equipped. 3. CD Rom, DVD or OEM web based repair information is acceptable. 4. Web based OEM repair information provided for this bid shall be dealer/vendor authorized and provided throughout the unit(s) life cycle within the City Fleet. 			
EXCEPTIONS:			

SPECIFICATIONS	Bid der Complies	YES	NO
<p>38.0/ - WARRANTY:</p> <ol style="list-style-type: none"> 1. Manufacturer's full warranty shall be applicable to this unit(s) as equipped (12 month, 12,000 miles, Unlimited Hours, minimum). 2. Awarded vendor shall be required to reimburse any expenses incurred by the City covering transport labor cost or shipment charges on any unit component or attached component failure when the unit or component manufacturer requires an "Authorized dealer repair only" and when the authorized repair facility extends beyond a fifty (50) mile radius of the City of Kingsport city limits during the warranty period. 3. Towing and hauling service to a repair facility shall be provided at "no cost" to the City of Kingsport throughout the complete warranty period of the unit on any of the incorporated components or attachments on the unit. 4. The awarded vendor shall be required to reimburse the City of Kingsport for any and all unit warranty repair expenses, to include towing or hauling services, incurred by the City of Kingsport during the warranty period. 5. Reimbursement shall occur within a maximum of 30 days of notification of a reimbursement claim. 6. Awarded vendor shall agree to perform, or have performed, any and all warranty work on the unit and any installed attachment(s) or unit component throughout the complete warranty period which will begin at the time the unit(s) are placed into active service. 7. This specifications requires manufacturer's delayed warranty start. 8. Chassis, components, all attachments and body shall have a minimum 100% full warranty (parts and labor) for a minimum period of one (1) year from the time of cab/chassis/body service activation within the City of Kingsport fleet regardless of manufacturer or installer. 9. Warranty claims of any unit, component, or attachment shall be addressed within a period 3 days from time of notification by the awarded vendor. 10. Awarded vendor shall insure successful completion of any warranty repair within 10 business days from time of notification. 11. Towing service shall be provided though the warranty period for warrantable breakdowns requiring tow. 12. This warranty specification shall be honored in conjunction with any manufacturer's standard warranty regardless of exclusions. 			
<p>EXCEPTIONS:</p>			

SPECIFICATIONS	Bid der Complies	YES	NO
<p>39.0/ - DELIVERY:</p> <ol style="list-style-type: none"> 1. Unit(s) shall be delivered complete with all provided options installed and a full tank of fuel. 2. The Diesel Exhaust Fluid tank shall be full if applicable to the unit(s). 3. Unit(s) shall be delivered complete with NO dealer advertising logos affixed to the interior or exterior, to include mud-flaps, of the unit(s) prior to delivery. 4. Delivered unit(s) shall come with all required paperwork to complete the purchase and registration process and shall include at a minimum: <ol style="list-style-type: none"> a. Invoice b. Mileage Statement (if applicable) c. Manufacturer's Statement of Origin (MSO)(if applicable). 5. Delivery acceptance of unit(s) may be refused if any part of the awarded specifications are not maintained. 6. Delivery acceptance of unit(s) may be refused if any device, feature or system is deemed as unsafe to the operator and/or the general public as determined by the City of Kingsport's knowledge or experience. 7. Delivered unit(s) are required to complete an acceptance inspection (school buses will require the additional State of Tennessee inspection) and shall be inspected against awarded specifications as a total unit, irregardless of multiple manufacturer contributions to the completed elements of the unit(s), before acceptance is granted. 8. Bidder misunderstanding and/or misinterpretation which results in an unsatisfactory bid or final delivered product is not the responsibility of the City of Kingsport. 9. The City of Kingsport shall have the sole interpretation of the bid requirements and shall have final determination whether submitted bids and/or the final product delivered satisfy the requirements of the bid. 10. All awarded bids shall be subject to final inspection of the unit(s) ordered by the Fleet Manager, or designee, and must be compliant with all bid requirements prior to acceptance of the unit(s) and final payment. 11. Any non-compliant unit(s) must be made compliant at the expense of the awarded bidder and within a reasonable time frame, as determined by the City of Kingsport. 12. Misinterpretation of the specifications by the vendor or failure to supply the appropriately equipped unit(s) specified or intended, based on the City of Kingsport's interpretation, shall be corrected to the benefit of the City of Kingsport by the awarded bidder at the bidders expense. 13. In all cases the City of Kingsport's interpretation and definition of unit(s) specifications and requirements shall be the final determination of a successful final inspection and compliance with awarded specifications before unit acceptance will be granted. 14. Failure to provide the requested documentation upon delivery shall be considered as non-compliance to awarded specifications and allows the City of Kingsport the right to refuse acceptance. 15. All "Trade In" units offered by the City of Kingsport are to be considered "AS IS, WHERE IS". 16. Any trade terms offered or required by a bidder will allow the City of Kingsport to reject their bids. 			
EXCEPTIONS:			
<p>40.0/ - TRAINING:</p> <ol style="list-style-type: none"> 1. Successful bidder shall provide a minimum of three (3) hours of technician service/ repair training and/or operator training with-in the upper east part of the State of Tennessee. 2. This training shall present the manufactures required maintenance/repair or operating procedures and offer the technician or operator full knowledge of the practices required for the successful, lifelong operation of the proposed vehicle. 3. This training shall be provided within two (2) weeks of service activation of the unit(s). 4. The Transit Director, or designee, shall inform the vendor of the type of training required (technician or operator) when the units are to be placed into service. 			
EXCEPTIONS:			

Security Camera Location

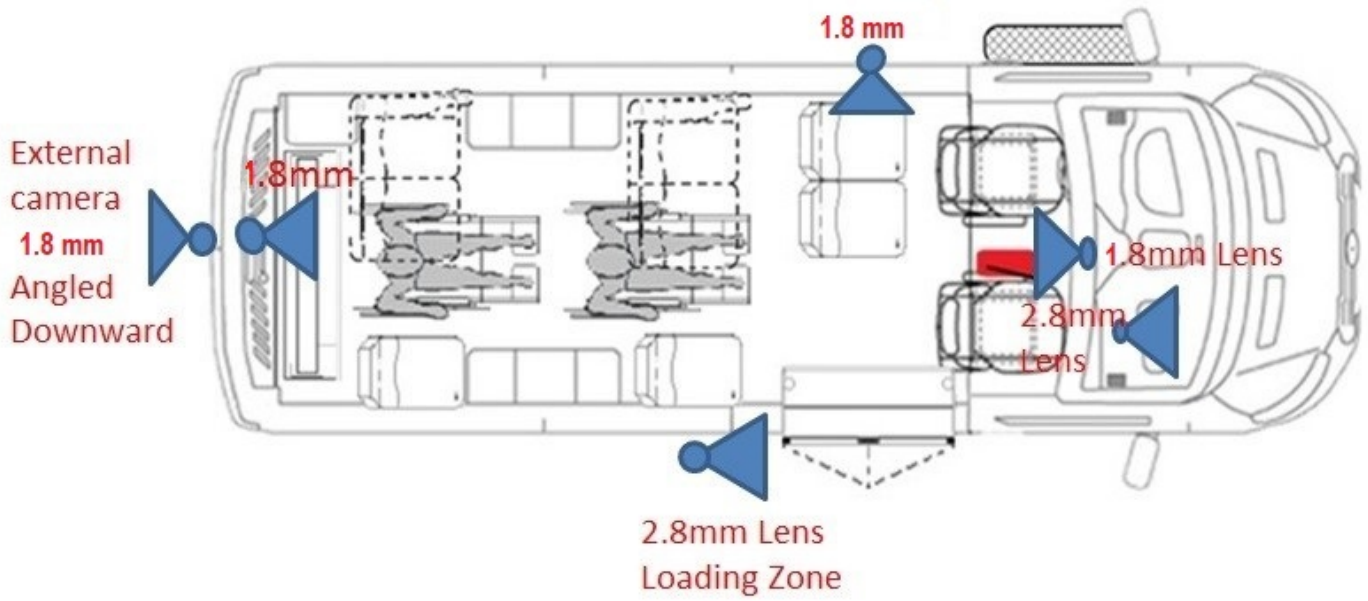

Seating Diagram 1

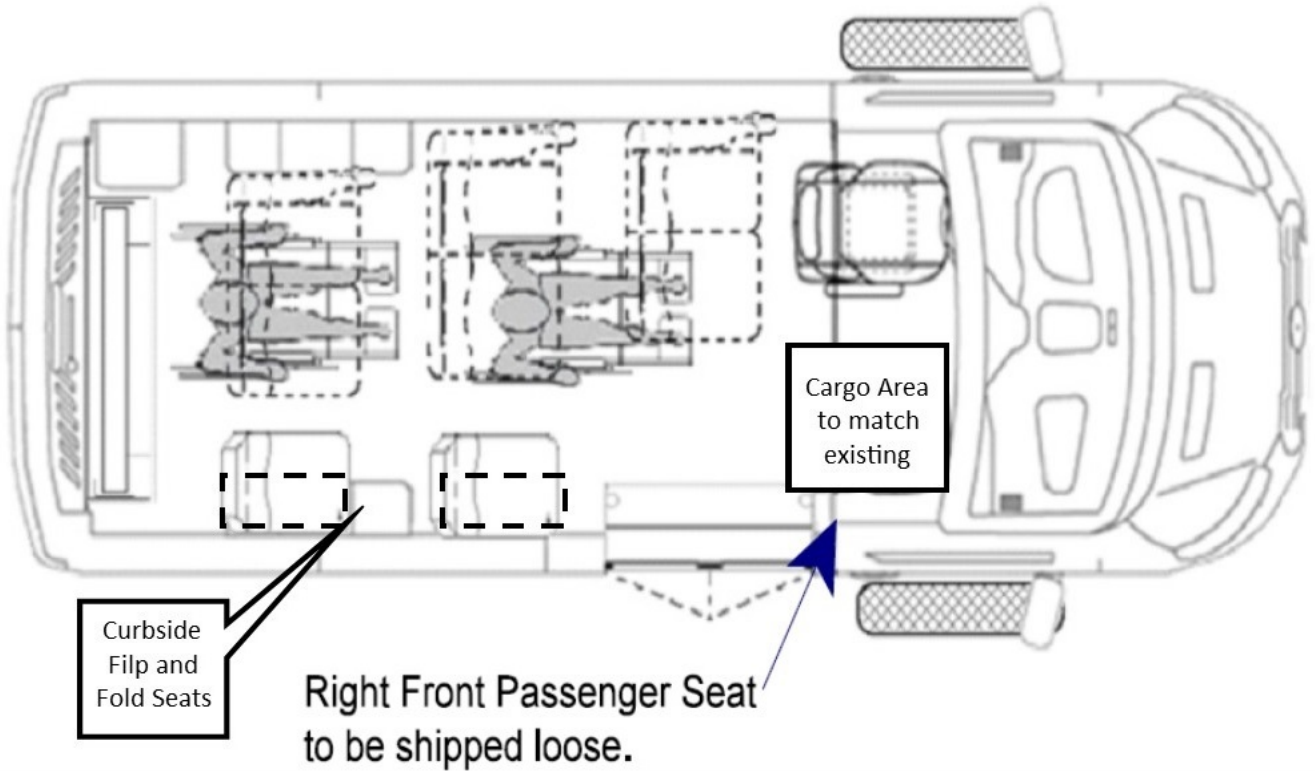

L TRACK Diagram 2

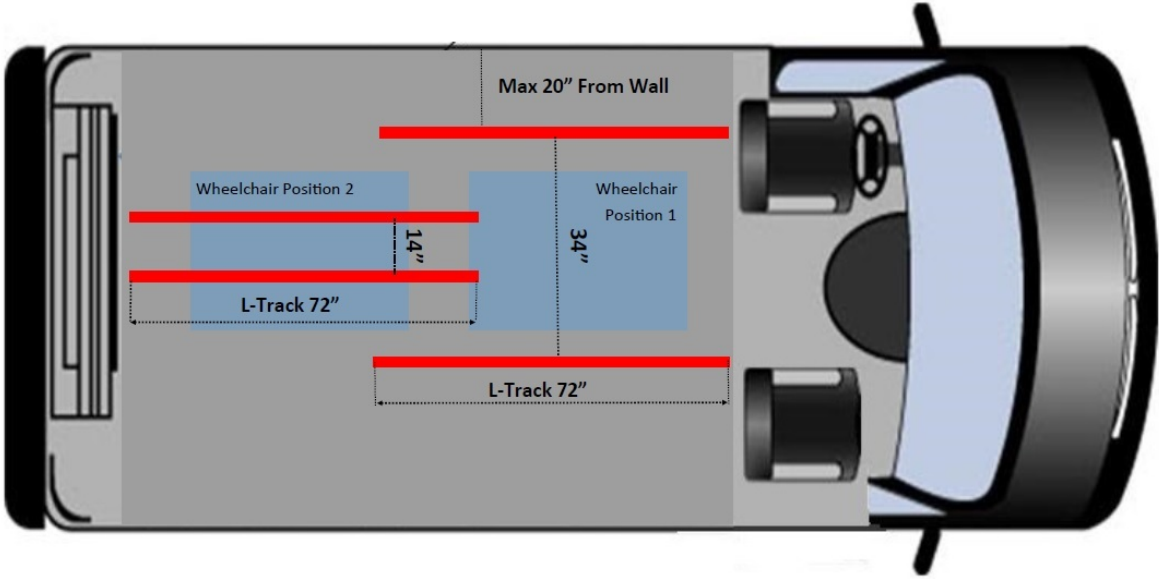

All contractors and/or subcontractors with the Kingsport Area Transit Service are required to meet the following federal requirements:

1. Disadvantaged Business Enterprise (DBE)
2. Bidder's Certification of Disadvantaged DBE/Transit Vehicle Manufactures Certification (*Return Signed Form with Bid Proposal*)
3. Buy America Requirements (*Return Signed Form with Bid Proposal*)
4. Pre-Award Buy America Requirements (*Included for information purposes only*)
5. Post-Award Buy America Requirements (*Included for information purposes only*)
6. Pre-Award Purchaser's Requirements (*Included for information purposes only*)
7. Post-Award Purchaser's Requirements (*Included for information purposes only*)
8. Pre-Award FMVSS Compliance Certification (*Included for information purposes only*)
9. Post-Award FMVSS Compliance Certification (*Included for information purposes only*)
10. Pre-Award and Post Delivery Audits Requirements (*Return Signed Form with Bid Proposal*)
11. Lobbying Certification (*Return Signed Form with Bid Proposal*)
12. Bus Testing (*Return Signed Form with Bid Proposal*)
13. Energy Conservation Requirements
14. Clean Water Requirements
15. Access to Records and Reports
16. Federal Changes
17. Clean Air
18. No Government Obligation to Third Parties
19. Program Fraud and False Statements and Related Acts
20. Termination Certification
21. Government Wide Debarment and Suspension (Nonprocurement)
22. Privacy Act
23. Civil Rights
24. Breaches and Dispute Resolution
25. ADA
26. Incorporation of Federal Transit Administration Terms
27. Contract work Hours & Safety Standards Act
28. Fly America Requirements
29. Intermodal Surface Transportation Efficiency Requirements (*Return Signed with Bid*)
30. Drug Free Workplace (*Return Signed Form with Bid Proposal*)
31. Rolling Stock Minimum Service Life (*Return Signed Form with Bid Proposal*)
32. Cargo Preference Requirements
33. City of Kingsport Protest Procedures
34. Bidders/Proposers List Information (*Return Signed Form with Bid Proposal*)

Additional information and description of the above requirements are available as requested. Signing this document certifies the vendor understands their responsibility to be in compliance with the above third party contract clauses. All the above contract clauses are attached with this document.

Signature of Authorized Representative

Name of Vendor

Date

DISADVANTAGED BUSINESS ENTERPRISE (DBE)

49 CFR Part 26

Disadvantaged Business Enterprises

- a. This contract is subject to the requirements of Title 49, Code of Federal Regulations, Part 26, *Participation by Disadvantaged Business Enterprises in Department of Transportation Financial Assistance Programs*. If it is a transit vehicle manufacturer the bidder certifies that it has complied with the requirements of 49 CFR 26 by submitting an annual DBE goal to the FTA. The goal has either been approved or not disapproved by FTA. The bidder, if a nonmanufacturer supplier hereby certifies that the manufacturer of the transit vehicle to be supplied has complied with the requirements of 49 CFR section 26.
- b. The contractor shall not discriminate on the basis of race, color, national origin, or sex in the performance of this contract. The contractor shall carry out applicable requirements of 49 CFR Part 26 in the award and administration of this DOT-assisted contract. Failure by the contractor to carry out these requirements is a material breach of this contract, which may result in the termination of this contract or such other remedy as Kingsport Area Transit Service deems appropriate. Each subcontract the contractor signs with a subcontractor must include the assurance in this paragraph (*see* 49 CFR 26.13(b)).
- c. The successful bidder/offeror will be required to report its DBE participation obtained through race-neutral means throughout the period of performance.
- d. The contractor is required to pay its subcontractors performing work related to this contract for satisfactory performance of that work no later than 30 days after the contractor's receipt of payment for that work from the City of Kingsport on behalf of Kingsport Area Transit Service (a department of the City of Kingsport). In addition, the contractor may not hold retainage from its subcontractors.
- e. The contractor must promptly notify Kingsport Area Transit Service, whenever a DBE subcontractor performing work related to this contract is terminated or fails to complete its work, and must make good faith efforts to engage another DBE subcontractor to perform at least the same amount of work. The contractor may not terminate any DBE subcontractor and perform that work through its own forces or those of an affiliate without prior written consent of Kingsport Area Transit Service.

BIDDER'S CERTIFICATION OF DISADVANTAGED BUSINESS ENTERPRISE (DBE)
TRANSIT VEHICLE MANUFACTURERS (TVM) CERTIFICATION

The Offeror, if a transit vehicle manufacturer, hereby certifies that it has complied with the requirements of Section 26.49 of 49 CFR Part 26 by submitting an annual DBE/WBE goal to the Federal Transit Administration (FTA). The goal has either been approved or not disapproved by FTA.

The Offeror, if a non-manufacturer supplier, hereby certifies that the manufacturer of the transit vehicle to be supplied has complied with the above-referenced requirement of Section 26.49 of 49 CFR Part 26.

DATE

COMPANY NAME

AUTHORIZED REPRESENTATIVE NAME (Printed)

TITLE

SIGNATURE of AUTHORIZED REPRESENTATIVE

RETURN SIGNED FORM WITH BID PROPOSAL.

BUY AMERICA REQUIREMENTS

49 U.S.C. 5323(j)

49 CFR Part 661

(FOR PROCUREMENT OF BUSES, ROLLING STOCK AND ASSOCIATED EQUIPMENT)

Buy America - The contractor agrees to comply with 49 U.S.C. 5323(j) and 49 C.F.R. Part 661, which provide that Federal funds may not be obligated unless steel, iron, and manufactured products used in FTA-funded projects are produced in the United States, unless a waiver has been granted by FTA or the product is subject to a general waiver. General waivers are listed in 49 C.F.R. 661.7, and include final assembly in the United States for 15 passenger vans and 15 passenger wagons produced by Chrysler Corporation, and microcomputer equipment and software. Separate requirements for rolling stock are set out at 49 U.S.C. 5323(j)(2)(C) and 49 C.F.R. 661.11. Rolling stock must be assembled in the United States and have a 60 percent domestic content.

A bidder or offeror must submit to the FTA recipient the appropriate Buy America certification (below) with all bids or offers on FTA-funded contracts, except those subject to a general waiver. Bids or offers that are not accompanied by a completed Buy America certification must be rejected as nonresponsive. This requirement does not apply to lower tier subcontractors.

Certification requirement for procurement of buses, other rolling stock and associated equipment.

Certificate of Compliance with 49 U.S.C. 5323(j)(2)(C).

The bidder or offeror hereby certifies that it will comply with the requirements of 49 U.S.C. 5323(j)(2)(C) and the regulations at 49 C.F.R. Part 661.11.

Date _____

Signature _____

Company Name _____

Title _____

Certificate of Non-Compliance with 49 U.S.C. 5323(j)(2)(C)

The bidder or offeror hereby certifies that it cannot comply with the requirements of 49 U.S.C. 5323(j)(2)(C) and 49 C.F.R. 661.11, but may qualify for an exception pursuant to 49 U.S.C. 5323(j)(2)(A), 5323(j)(2)(B), or 5323(j)(2)(D), and 49 CFR 661.7.

Date _____

Signature _____

Company Name _____

Title _____

Return signed form with bid proposal.

PRE-AWARD BUY AMERICA COMPLIANCE CERTIFICATION

As required by Title 49 of the CFR, Part 663 – Subpart B,

_____ (the recipient) is satisfied that the buses to be purchased, _____ (number and description of buses) from _____ (the manufacturer), meet the requirements of Section 165(b)(3) of the Surface Transportation Assistance Act of 1982, as amended. The recipient, or its appointed analyst _____ (the analyst – not the manufacturer or its agent), has reviewed documentation provided by the manufacturer, which lists (1) the proposed component and subcomponent parts of the buses identified by manufacturer, country of origin, and cost; and (2) the proposed location of the final assembly point for the buses, including a description of the activities that will take place at the final assembly point and the cost of final assembly.

Date: _____

Signature: _____ Title: _____

POST-DELIVERY BUY AMERICA COMPLIANCE CERTIFICATION

As required by Title 49 of the CFR, Part 663 – Subpart C, _____ (the recipient) certifies that it is satisfied that the buses received, _____ (number and description of buses) from _____ (the manufacturer), meet the requirements of Section 165(b)(3) of the Surface Transportation Assistance Act of 1982, as amended. The recipient, or its appointed analyst _____ (the analyst – not the manufacturer or its agent), has reviewed documentation provided by the manufacturer, which lists (1) the actual component and subcomponent parts of the buses identified by the manufacturer, country of origin, and cost; and (2) the actual location of the final assembly point for the buses, including a description of the activities that took place at the final assembly point and the cost of final assembly.

Date: _____

Signature: _____ Title: _____

PRE-AWARD PURCHASER'S REQUIREMENTS CERTIFICATION

As required by Title 49 of the CFR, Part 663 – Subpart B,

_____ (the recipient)
certifies that the buses to be purchased, _____ (number
and description of buses) from _____ (the
manufacturer), are the same product described in the recipient's solicitation specification and
that the proposed manufacturer is a responsible manufacturer with the capability to produce a bus
that meets the specifications.

Date: _____

Signature: _____ Title: _____

POST-DELIVERY PURCHASER'S REQUIREMENTS CERTIFICATION

As required by Title 49 of the CFR, Part 663 – Subpart C, after visually inspecting and road testing the contract buses, (the recipient) certifies that the buses, _____

_____ (number and description of buses) from _____ (the manufacturer), meet the contract specifications.

Date: _____

Signature: _____ Title: _____

PRE-AWARD FMVSS COMPLIANCE CERTIFICATION

As required by Title 49 of the CFR, Part 663 – Subpart D,
_____ (the recipient) certifies that it received, at the pre-award
stage, a copy of _____'s (the manufacturer) self-certification
information stating that the buses, _____ (number and description of buses),
will comply with the relevant Federal Motor Vehicle Safety Standards issued by the National
Highway Traffic Safety Administration in Title 49 of the Code of Federal Regulations, Part 571.

Date: _____

Signature: _____ Title: _____

POST-DELIVERY FMVSS COMPLIANCE CERTIFICATION

As required by Title 49 of the CFR, Part 663 – Subpart D, _____
_____(the recipient) certifies that it received, at the post-delivery stage, a copy of
_____'s (the manufacturer) self-certification information stating that the buses,
_____(number and description of buses), comply
with the relevant Federal Motor Vehicle Safety Standards issued by the National Highway
Traffic Safety Administration in Title 49 Code of Federal Regulations, Part 571.

Date: _____

Signature: _____ Title: _____

PRE-AWARD AND POST DELIVERY AUDITS REQUIREMENTS

49 U.S.C. 5323

49 CFR Part 663

(Return signed form with bid proposal.)

Pre-Award and Post-Delivery Audit Requirements - The Contractor agrees to comply with 49 U.S.C. § 5323(l) and FTA's implementing regulation at 49 C.F.R. Part 663 and to submit the following certifications:

(1) Buy America Requirements: The Contractor shall complete and submit a declaration certifying either compliance or noncompliance with Buy America. If the Bidder/Offeror certifies compliance with Buy America, it shall submit documentation which lists 1) component and subcomponent parts of the rolling stock to be purchased identified by manufacturer of the parts, their country of origin and costs; and 2) the location of the final assembly point for the rolling stock, including a description of the activities that will take place at the final assembly point and the cost of final assembly.

(2) Solicitation Specification Requirements: The Contractor shall submit evidence that it will be capable of meeting the bid specifications.

(3) Federal Motor Vehicle Safety Standards (FMVSS): The Contractor shall submit 1) manufacturer's FMVSS self-certification sticker information that the vehicle complies with relevant FMVSS or 2) manufacturer's certified statement that the contracted buses will not be subject to FMVSS regulations.

Certificate of Compliance

The bidder hereby certifies that it will comply with the requirements of 49 U.S.C. Section 5323(j)(2)(C), Section 165(b)(3) of the Surface Transportation Assistance Act of 1982, as amended, and the regulations of 49 C.F.R. 661.11:

Date: _____

Signature: _____

Company Name: _____

Title: _____

Certificate of Non-Compliance

The bidder hereby certifies that it cannot comply with the requirements of 49 U.S.C. Section 5323(j)(2)(C) and Section 165(b)(3) of the Surface Transportation Assistance Act of 1982, as amended, but may qualify for an exception to the requirements consistent with 49 U.S.C. Sections 5323(j)(2)(B) or (j)(2)(D), Sections 165(b)(2) or (b)(4) of the Surface Transportation Assistance Act, as amended, and regulations in 49 C.F.R. 661.7.

Date: _____

Signature: _____

Company Name: _____

Title: _____

LOBBYING
31 U.S.C. 1352
49 CFR Part 19
49 CFR Part 20

(Return signed form with bid proposal.)

The undersigned [Contractor] certifies, to the best of his or her knowledge and belief, that:

(1) No Federal appropriated funds have been paid or will be paid, by or on behalf of the undersigned, to any person for influencing or attempting to influence an officer or employee of an agency, a Member of Congress, an officer or employee of Congress, or an employee of a Member of Congress in connection with the awarding of any Federal contract, the making of any Federal grant, the making of any Federal loan, the entering into of any cooperative agreement, and the extension, continuation, renewal, amendment, or modification of any Federal contract, grant, loan, or cooperative agreement.

(2) If any funds other than Federal appropriated funds have been paid or will be paid to any person for making lobbying contacts to an officer or employee of any agency, a Member of Congress, an officer or employee of Congress, or an employee of a Member of Congress in connection with this Federal contract, grant, loan, or cooperative agreement, the undersigned shall complete and submit Standard Form--LLL, "Disclosure Form to Report Lobbying," in accordance with its instructions [as amended by "Government wide Guidance for New Restrictions on Lobbying," 61 Fed. Reg. 1413 (1/19/96). Note: Language in paragraph (2) herein has been modified in accordance with Section 10 of the Lobbying Disclosure Act of 1995 (P.L. 104-65, to be codified at 2 U.S.C. 1601, *et seq.*)]

(3) The undersigned shall require that the language of this certification be included in the award documents for all subawards at all tiers (including subcontracts, subgrants, and contracts under grants, loans, and cooperative agreements) and that all subrecipients shall certify and disclose accordingly.

This certification is a material representation of fact upon which reliance was placed when this transaction was made or entered into. Submission of this certification is a prerequisite for making or entering into this transaction imposed by 31, U.S.C. § 1352 (as amended by the Lobbying Disclosure Act of 1995). Any person who fails to file the required certification shall be subject to a civil penalty of not less than \$10,000 and not more than \$100,000 for each such failure.

[Note: Pursuant to 31 U.S.C. § 1352(c)(1)-(2)(A), any person who makes a prohibited expenditure or fails to file or amend a required certification or disclosure form shall be subject to a civil penalty of not less than \$10,000 and not more than \$100,000 for each such expenditure or failure.]

The Contractor, _____, certifies or affirms the truthfulness and accuracy of each statement of its certification and disclosure, if any. In addition, the Contractor understands and agrees that the provisions of 31 U.S.C. A 3801, *et seq.*, apply to this certification and disclosure, if any.

_____ Signature of Contractor's Authorized Official

_____ Name and Title of Contractor's Authorized Official

_____ Date

BUS TESTING
49 U.S.C. 5323(c)
49 CFR Part 665

Bus Testing - The Contractor [Manufacturer] agrees to comply with 49 U.S.C. A 5323(c) and FTA's implementing regulation at 49 CFR Part 665 and shall perform the following:

- 1) A manufacturer of a new bus model or a bus produced with a major change in components or configuration shall provide a copy of the final test report to the recipient at a point in the procurement process specified by the recipient which will be prior to the recipient's final acceptance of the first vehicle.
- 2) A manufacturer who releases a report under paragraph 1 above shall provide notice to the operator of the testing facility that the report is available to the public.
- 3) If the manufacturer represents that the vehicle was previously tested, the vehicle being sold should have the identical configuration and major components as the vehicle in the test report, which must be provided to the recipient prior to recipient's final acceptance of the first vehicle. If the configuration or components are not identical, the manufacturer shall provide a description of the change and the manufacturer's basis for concluding that it is not a major change requiring additional testing.
- 4) If the manufacturer represents that the vehicle is "grandfathered" (has been used in mass transit service in the United States before October 1, 1988, and is currently being produced without a major change in configuration or components), the manufacturer shall provide the name and address of the recipient of such a vehicle and the details of that vehicle's configuration and major components.

CERTIFICATION OF COMPLIANCE WITH FTA'S BUS TESTING REQUIREMENTS
The undersigned [Contractor/Manufacturer] certifies that the vehicle offered in this procurement complies with 49 U.S.C. A 5323(c) and FTA's implementing regulation at 49 CFR Part 665.

The undersigned understands that misrepresenting the testing status of a vehicle acquired with Federal financial assistance may subject the undersigned to civil penalties as outlined in the Department of Transportation's regulation on Program Fraud Civil Remedies, 49 CFR Part 31. In addition, the undersigned understands that FTA may suspend or debar a manufacturer under the procedures in 49 CFR Part 29.

Date: _____

Signature: _____

Company Name: _____

Title: _____

Return signed form with bid proposal.

ENERGY CONSERVATION REQUIREMENTS

42 U.S.C. 6321 et seq.

49 CFR Part 18

Energy Conservation - The contractor agrees to comply with mandatory standards and policies relating to energy efficiency which are contained in the state energy conservation plan issued in compliance with the Energy Policy and Conservation Act.

CLEAN WATER REQUIREMENTS
33 U.S.C. 1251

Clean Water - (1) The Contractor agrees to comply with all applicable standards, orders or regulations issued pursuant to the Federal Water Pollution Control Act, as amended, 33 U.S.C. 1251 et seq. The Contractor agrees to report each violation to the Purchaser and understands and agrees that the Purchaser will, in turn, report each violation as required to assure notification to FTA and the appropriate EPA Regional Office.

(2) The Contractor also agrees to include these requirements in each subcontract exceeding \$100,000 financed in whole or in part with Federal assistance provided by FTA.

ACCESS TO RECORDS AND REPORTS

49 U.S.C. 5325

18 CFR 18.36 (i)

49 CFR 633.17

Access to Records - The following access to records requirements apply to this Contract:

1. Where the Purchaser is not a State but a local government and is the FTA Recipient or a subgrantee of the FTA Recipient in accordance with 49 C.F.R. 18.36(i), the Contractor agrees to provide the Purchaser, the FTA Administrator, the Comptroller General of the United States or any of their authorized representatives access to any books, documents, papers and records of the Contractor which are directly pertinent to this contract for the purposes of making audits, examinations, excerpts and transcriptions. Contractor also agrees, pursuant to 49 C.F.R. 633.17 to provide the FTA Administrator or his authorized representatives including any PMO Contractor access to Contractor's records and construction sites pertaining to a major capital project, defined at 49 U.S.C. 5302(a)1, which is receiving federal financial assistance through the programs described at 49 U.S.C. 5307, 5309 or 5311.
2. Where any Purchaser which is the FTA Recipient or a subgrantee of the FTA Recipient in accordance with 49 U.S.C. 5325(a) enters into a contract for a capital project or improvement (defined at 49 U.S.C. 5302(a)1) through other than competitive bidding, the Contractor shall make available records related to the contract to the Purchaser, the Secretary of Transportation and the Comptroller General or any authorized officer or employee of any of them for the purposes of conducting an audit and inspection.
3. The Contractor agrees to permit any of the foregoing parties to reproduce by any means whatsoever or to copy excerpts and transcriptions as reasonably needed.
4. The Contractor agrees to maintain all books, records, accounts and reports required under this contract for a period of not less than three years after the date of termination or expiration of this contract, except in the event of litigation or settlement of claims arising from the performance of this contract, in which case Contractor agrees to maintain same until the Purchaser, the FTA Administrator, the Comptroller General, or any of their duly authorized representatives, have disposed of all such litigation, appeals, claims or exceptions related thereto. Reference 49 CFR 18.39(i)(11).
5. FTA does not require the inclusion of these requirements in subcontracts.

FEDERAL CHANGES
49 CFR Part 18

Federal Changes - Contractor shall at all times comply with all applicable FTA regulations, policies, procedures and directives, including without limitation those listed directly or by reference in the Agreement (Form FTA MA(10) dated October, 2003) between Purchaser and FTA, as they may be amended or promulgated from time to time during the term of this contract. Contractor's failure to so comply shall constitute a material breach of this contract.

CLEAN AIR
42 U.S.C. 7401 et seq
40 CFR 15.61
49 CFR Part 18

Clean Air - (1) The Contractor agrees to comply with all applicable standards, orders or regulations issued pursuant to the Clean Air Act, as amended, 42 U.S.C. §§ 7401 et seq. The Contractor agrees to report each violation to the Purchaser and understands and agrees that the Purchaser will, in turn, report each violation as required to assure notification to FTA and the appropriate EPA Regional Office.

(2) The Contractor also agrees to include these requirements in each subcontract exceeding \$100,000 financed in whole or in part with Federal assistance provided by FTA.

NO GOVERNMENT OBLIGATION TO THIRD PARTIES

No Obligation by the Federal Government.

(1) The Purchaser and Contractor acknowledge and agree that, notwithstanding any concurrence by the Federal Government in or approval of the solicitation or award of the underlying contract, absent the express written consent by the Federal Government, the Federal Government is not a party to this contract and shall not be subject to any obligations or liabilities to the Purchaser, Contractor, or any other party (whether or not a party to that contract) pertaining to any matter resulting from the underlying contract.

(2) The Contractor agrees to include the above clause in each subcontract financed in whole or in part with Federal assistance provided by FTA. It is further agreed that the clause shall not be modified, except to identify the subcontractor who will be subject to its provisions.

PROGRAM FRAUD AND FALSE OR FRAUDULENT STATEMENTS
AND RELATED ACTS
31 U.S.C. 3801 et seq.
49 CFR Part 31 18 U.S.C. 1001
49 U.S.C. 5307

Program Fraud and False or Fraudulent Statements or Related Acts.

(1) The Contractor acknowledges that the provisions of the Program Fraud Civil Remedies Act of 1986, as amended, 31 U.S.C. § 3801 et seq. and U.S. DOT regulations, "Program Fraud Civil Remedies," 49 C.F.R. Part 31, apply to its actions pertaining to this Project. Upon execution of the underlying contract, the Contractor certifies or affirms the truthfulness and accuracy of any statement it has made, it makes, it may make, or causes to be made, pertaining to the underlying contract or the FTA assisted project for which this contract work is being performed. In addition to other penalties that may be applicable, the Contractor further acknowledges that if it makes, or causes to be made, a false, fictitious, or fraudulent claim, statement, submission, or certification, the Federal Government reserves the right to impose the penalties of the Program Fraud Civil Remedies Act of 1986 on the Contractor to the extent the Federal Government deems appropriate.

(2) The Contractor also acknowledges that if it makes, or causes to be made, a false, fictitious, or fraudulent claim, statement, submission, or certification to the Federal Government under a contract connected with a project that is financed in whole or in part with Federal assistance originally awarded by FTA under the authority of 49 U.S.C. § 5307, the Government reserves the right to impose the penalties of 18 U.S.C. § 1001 and 49 U.S.C. § 5307(n)(1) on the Contractor, to the extent the Federal Government deems appropriate.

(3) The Contractor agrees to include the above two clauses in each subcontract financed in whole or in part with Federal assistance provided by FTA. It is further agreed that the clauses shall not be modified, except to identify the subcontractor who will be subject the provisions.

TERMINATION
49 U.S.C. Part 18
FTA Circular 4220.1E

(Supplies and Service)

a. Termination for Convenience (General Provision) The City of Kingsport / Kingsport Area Transit Service may terminate this contract, in whole or in part, at any time by written notice to the Contractor when it is in the Government's best interest. The Contractor shall be paid its costs, including contract close-out costs, and profit on work performed up to the time of termination. The Contractor shall promptly submit its termination claim to the City of Kingsport / Kingsport Area Transit Service to be paid the Contractor. If the Contractor has any property in its possession belonging to the City of Kingsport / Kingsport Area Transit Service, the Contractor will account for the same, and dispose of it in the manner the Kingsport / Kingsport Area Transit Service directs.

b. Termination for Default [Breach or Cause] (General Provision) If the Contractor does not deliver supplies in accordance with the contract delivery schedule, or, if the contract is for services, the Contractor fails to perform in the manner called for in the contract, or if the Contractor fails to comply with any other provisions of the contract, the City of Kingsport / Kingsport Area Transit Service may terminate this contract for default. Termination shall be effected by serving a notice of termination on the contractor setting forth the manner in which the Contractor is in default. The contractor will only be paid the contract price for supplies delivered and accepted, or services performed in accordance with the manner of performance set forth in the contract.

If it is later determined by the City of Kingsport / Kingsport Area Transit Service that the Contractor had an excusable reason for not performing, such as a strike, fire, or flood, events which are not the fault of or are beyond the control of the Contractor, the Kingsport / Kingsport Area Transit Service, after setting up a new delivery of performance schedule, may allow the Contractor to continue work, or treat the termination as a termination for convenience.

c. Opportunity to Cure (General Provision) The City of Kingsport / Kingsport Area Transit Service in its sole discretion may, in the case of a termination for breach or default, allow the Contractor [an appropriately short period of time] in which to cure the defect. In such case, the notice of termination will state the time period in which cure is permitted and other appropriate conditions

If Contractor fails to remedy to the City of Kingsport / Kingsport Area Transit Service satisfaction the breach or default of any of the terms, covenants, or conditions of this Contract within [ten (10) days] after receipt by Contractor of written notice from the Kingsport / Kingsport Area Transit Service setting forth the nature of said breach or default, the City of Kingsport / Kingsport Area Transit Service shall have the right to terminate the Contract without any further obligation to Contractor. Any such termination for default shall not in any way operate to preclude the City of Kingsport / Kingsport Area Transit Service from also pursuing all available remedies against Contractor and its sureties for said breach or default.

d. Waiver of Remedies for any Breach In the event that the City of Kingsport / Kingsport Area Transit Service elects to waive its remedies for any breach by Contractor of any covenant, term or condition of this Contract, such waiver by the City of Kingsport / Kingsport Area Transit Service shall not limit the City of Kingsport / Kingsport Area Transit Service's remedies for any succeeding breach of that or of any other term, covenant, or condition of this Contract.

GOVERNMENT-WIDE DEBARMENT AND SUSPENSION (NONPROCUREMENT)

Suspension and Debarment

This contract is a covered transaction for purposes of 49 CFR Part 29. As such, the contractor is required to verify that none of the contractor, its principals, as defined at 49 CFR 29.995, or affiliates, as defined at 49 CFR 29.905, are excluded or disqualified as defined at 49 CFR 29.940 and 29.945.

The contractor is required to comply with 49 CFR 29, Subpart C and must include the requirement to comply with 49 CFR 29, Subpart C in any lower tier covered transaction it enters into.

By signing and submitting its bid or proposal, the bidder or proposer certifies as follows:

The certification in this clause is a material representation of fact relied upon by the City of Kingsport / Kingsport Area Transit Service. If it is later determined that the bidder or proposer knowingly rendered an erroneous certification, in addition to remedies available to the City of Kingsport / Kingsport Area Transit Service, the Federal Government may pursue available remedies, including but not limited to suspension and/or debarment. The bidder or proposer agrees to comply with the requirements of 49 CFR 29, Subpart C while this offer is valid and throughout the period of any contract that may arise from this offer. The bidder or proposer further agrees to include a provision requiring such compliance in its lower tier covered transactions.

PRIVACY ACT
5 U.S.C. 552

Contracts Involving Federal Privacy Act Requirements - The following requirements apply to the Contractor and its employees that administer any system of records on behalf of the Federal Government under any contract:

(1) The Contractor agrees to comply with, and assures the compliance of its employees with, the information restrictions and other applicable requirements of the Privacy Act of 1974,

5 U.S.C. § 552a. Among other things, the Contractor agrees to obtain the express consent of the Federal Government before the Contractor or its employees operate a system of records on behalf of the Federal Government. The Contractor understands that the requirements of the Privacy Act, including the civil and criminal penalties for violation of that Act, apply to those individuals involved, and that failure to comply with the terms of the Privacy Act may result in termination of the underlying contract.

(2) The Contractor also agrees to include these requirements in each subcontract to administer any system of records on behalf of the Federal Government financed in whole or in part with Federal assistance provided by FTA.

CIVIL RIGHTS REQUIREMENTS

**29 U.S.C. § 623, 42 U.S.C. § 2000; 42 U.S.C. § 6102, 42 U.S.C. § 12112;
42 U.S.C. § 12132, 49 U.S.C. § 5332; 29 CFR Part 1630, 41 CFR Parts 60 et seq.**

Civil Rights - The following requirements apply to the underlying contract:

(1) Nondiscrimination - In accordance with Title VI of the Civil Rights Act, as amended, 42 U.S.C. § 2000d, section 303 of the Age Discrimination Act of 1975, as amended, 42 U.S.C. § 6102, section 202 of the Americans with Disabilities Act of 1990, 42 U.S.C. § 12132, and Federal transit law at 49 U.S.C. § 5332, the Contractor agrees that it will not discriminate against any employee or applicant for employment because of race, color, creed, national origin, sex, age, or disability. In addition, the Contractor agrees to comply with applicable Federal implementing regulations and other implementing requirements FTA may issue.

(2) Equal Employment Opportunity - The following equal employment opportunity requirements apply to the underlying contract:

(a) Race, Color, Creed, National Origin, Sex - In accordance with Title VII of the Civil Rights Act, as amended, 42 U.S.C. § 2000e, and Federal transit laws at 49 U.S.C. § 5332, the Contractor agrees to comply with all applicable equal employment opportunity requirements of U.S. Department of Labor (U.S. DOL) regulations, "Office of Federal Contract Compliance Programs, Equal Employment Opportunity, Department of Labor," 41 C.F.R. Parts 60 et seq., (which implement Executive Order No. 11246, "Equal Employment Opportunity," as amended by Executive Order No. 11375, "Amending Executive Order 11246 Relating to Equal Employment Opportunity," 42 U.S.C. § 2000e note), and with any applicable Federal statutes, executive orders, regulations, and Federal policies that may in the future affect construction activities undertaken in the course of the Project. The Contractor agrees to take affirmative action to ensure that applicants are employed, and that employees are treated during employment, without regard to their race, color, creed, national origin, sex, or age. Such action shall include, but not be limited to, the following: employment, upgrading, demotion or transfer, recruitment or recruitment advertising, layoff or termination; rates of pay or other forms of compensation; and selection for training, including apprenticeship. In addition, the Contractor agrees to comply with any implementing requirements FTA may issue.

(b) Age - In accordance with section 4 of the Age Discrimination in Employment Act of 1967, as amended, 29 U.S.C. § § 623 and Federal transit law at 49 U.S.C. § 5332, the Contractor agrees to refrain from discrimination against present and prospective employees for reason of age. In addition, the Contractor agrees to comply with any implementing requirements FTA may issue.

(c) Disabilities - In accordance with section 102 of the Americans with Disabilities Act, as amended, 42 U.S.C. § 12112, the Contractor agrees that it will comply with the requirements of U.S. Equal Employment Opportunity Commission, "Regulations to Implement the Equal Employment Provisions of the Americans with Disabilities Act," 29 C.F.R. Part 1630, pertaining to employment of persons with disabilities. In addition, the Contractor agrees to comply with any implementing requirements FTA may issue.

(3) The Contractor also agrees to include these requirements in each subcontract financed in whole or in part with Federal assistance provided by FTA, modified only if necessary to identify the affected parties.

BREACHES AND DISPUTE RESOLUTION

49 CFR Part 18

FTA Circular 4220.1E

Disputes - Disputes arising in the performance of this Contract which are not resolved by agreement of the parties shall be decided in writing by the authorized representative of the City of Kingsport / Kingsport Area Transit Service's Director. This decision shall be final and conclusive unless within [ten (10)] days from the date of receipt of its copy, the Contractor mails or otherwise furnishes a written appeal to the Director of Transit. In connection with any such appeal, the Contractor shall be afforded an opportunity to be heard and to offer evidence in support of its position. The decision of the Director of Transit shall be binding upon the Contractor and the Contractor shall abide by the decision.

Performance During Dispute - Unless otherwise directed by the City of Kingsport / Kingsport Area Transit Service, Contractor shall continue performance under this Contract while matters in dispute are being resolved.

Claims for Damages - Should either party to the Contract suffer injury or damage to person or property because of any act or omission of the party or of any of his employees, agents or others for whose acts he is legally liable, a claim for damages therefore shall be made in writing to such other party within a reasonable time after the first observance of such injury or damage.

Remedies - Unless this contract provides otherwise, all claims, counterclaims, disputes and other matters in question between the City of Kingsport / Kingsport Area Transit Service and the Contractor arising out of or relating to this agreement or its breach will be decided by arbitration if the parties mutually agree, or in a court of competent jurisdiction within the State in which the City of Kingsport / Kingsport Area Transit Service is located.

Rights and Remedies - The duties and obligations imposed by the Contract Documents and the rights and remedies available thereunder shall be in addition to and not a limitation of any duties, obligations, rights and remedies otherwise imposed or available by law. No action or failure to act by the City of Kingsport / Kingsport Area Transit Service, (Architect) or Contractor shall constitute a waiver of any right or duty afforded any of them under the Contract, nor shall any such action or failure to act constitute an approval of or acquiescence in any breach thereunder, except as may be specifically agreed in writing.

ADA

Contractor shall ensure that the vehicles meet the requirements of the Americans with Disabilities Act, Accessibility Specifications for Transportation Vehicles (49 CFR Part 38).

INCORPORATION OF FEDERAL TRANSIT ADMINISTRATION (FTA) TERMS
FTA Circular 4220.1E

Incorporation of Federal Transit Administration (FTA) Terms - The preceding provisions include, in part, certain Standard Terms and Conditions required by DOT, whether or not expressly set forth in the preceding contract provisions. All contractual provisions required by DOT, as set forth in FTA Circular 4220.1E, are hereby incorporated by reference. Anything to the contrary herein notwithstanding, all FTA mandated terms shall be deemed to control in the event of a conflict with other provisions contained in this Agreement. The Contractor shall not perform any act, fail to perform any act, or refuse to comply with any City of Kingsport / Kingsport Area Transit Service s requests which would cause the City of Kingsport / Kingsport Area Transit Service to be in violation of the FTA terms and conditions.

CONTRACT WORK HOURS AND SAFETY STANDARDS ACT

Contract Work Hours and Safety Standards

(1) **Overtime requirements** - No contractor or subcontractor contracting for any part of the contract work which may require or involve the employment of laborers or mechanics shall require or permit any such laborer or mechanic in any workweek in which he or she is employed on such work to work in excess of forty hours in such workweek unless such laborer or mechanic receives compensation at a rate not less than one and one-half times the basic rate of pay for all hours worked in excess of forty hours in such workweek.

(2) **Violation; liability for unpaid wages; liquidated damages** - In the event of any violation of the clause set forth in paragraph (1) of this section the contractor and any subcontractor responsible therefor shall be liable for the unpaid wages. In addition, such contractor and subcontractor shall be liable to the United States for liquidated damages. Such liquidated damages shall be computed with respect to each individual laborer or mechanic, including watchmen and guards, employed in violation of the clause set forth in paragraph (1) of this section, in the sum of \$10 for each calendar day on which such individual was required or permitted to work in excess of the standard workweek of forty hours without payment of the overtime wages required by the clause set forth in paragraph (1) of this section.

(3) **Withholding for unpaid wages and liquidated damages** - The (write in the name of the grantee) shall upon its own action or upon written request of an authorized representative of the Department of Labor withhold or cause to be withheld, from any moneys payable on account of work performed by the contractor or subcontractor under any such contract or any other Federal contract with the same prime contractor, or any other federally-assisted contract subject to the Contract Work Hours and Safety Standards Act, which is held by the same prime contractor, such sums as may be determined to be necessary to satisfy any liabilities of such contractor or subcontractor for unpaid wages and liquidated damages as provided in the clause set forth in paragraph (2) of this section.

(4) **Subcontracts** - The contractor or subcontractor shall insert in any subcontracts the clauses set forth in paragraphs (1) through (4) of this section and also a clause requiring the subcontractors to include these clauses in any lower tier subcontracts. The prime contractor shall be responsible for compliance by any subcontractor or lower tier subcontractor with the clauses set forth in paragraphs (1) through (4) of this section.

FLY AMERICA REQUIREMENTS

49 U.S.C. §40118
41 CFR Part 301-10

Applicability to Contracts

The Fly America requirements apply to the transportation of persons or property, by air, between a place in the U.S. and a place outside the U.S., or between places outside the U.S., when the FTA will participate in the costs of such air transportation. Transportation on a foreign air carrier is permissible when provided by a foreign air carrier under a code share agreement when the ticket identifies the U.S. air carrier's designator code and flight number.

Transportation by a foreign air carrier is also permissible if there is a bilateral or multilateral air transportation agreement to which the U.S. Government and a foreign government are parties and which the Federal DOT has determined meets the requirements of the Fly America Act.

Applicability to Micro-Purchases

Micro-purchases are defined as those purchases under \$2,500. These requirements do not apply to micro-purchases.

Flow Down Requirements

The Fly America requirements flow down from FTA recipients and subrecipients to first tier contractors, who are responsible for ensuring that lower tier contractors and subcontractors are in compliance.

Model Clause/Language

The relevant statutes and regulations do not mandate any specified clause or language. FTA proposes the following language.

Fly America Requirements - The Contractor agrees to comply with 49 U.S.C. 40118 (the "Fly America" Act) in accordance with the General Services Administration's regulations at 41 CFR Part 301-10, which provide that recipients and subrecipients of Federal funds and their contractors are required to use U.S. Flag air carriers for U.S Government-financed international air travel and transportation of their personal effects or property, to the extent such service is available, unless travel by foreign air carrier is a matter of necessity, as defined by the Fly America Act. The Contractor shall submit, if a foreign air carrier was used, an appropriate certification or memorandum adequately explaining why service by a U.S. flag air carrier was not available or why it was necessary to use a foreign air carrier and shall, in any event, provide a certificate of compliance with the Fly America requirements. The Contractor agrees to include the requirements of this section in all subcontracts that may involve international air transportation.

**CERTIFICATION OF COMPLIANCE
WITH
FEDERAL TRANSIT ACT
AND
INTERMODAL SURFACE TRANSPORTATION EFFICIENCY
ACT**

That _____
Name of Bidder

hereby certifies that it will comply with all regulations and requirements of the Federal Transit Act, as amended and the Intermodal Surface Transportation Efficiency Act of 1991, as amended.

Name of Firm

Address

City State Zip

Telephone

Authorized Person Name and Title (Type or Print)

Signature of Authorized Person Date

**CERTIFICATION REGARDING DRUG-FREE
WORKPLACE REQUIREMENTS**

That _____
Name of Bidder

hereby certifies that it will comply with Federal Transit Administration regulations regarding Drug-Free Workplace Requirements.

Name of Firm

Address

City State Zip

Telephone

Authorized Person Name and Title (Type or Print)

Signature of Authorized Person Date

**MANUFACTURER'S CERTIFICATION
OF
ROLLING STOCK MINIMUM SERVICE LIFE**

That _____
Name of Bidder

hereby certifies that the _____
vehicle(s) offered by this bid have been designed, manufactured, assembled, tested
and is in compliance with the Federal Transit Administration's requirements and
regulations concerning rolling stock minimum service life requirements. The bus that
is being bid has a minimum service life of _____ years and/or an accumulation
of _____ miles.

Name of Firm

Address

City State Zip

Telephone

Authorized Person Name and Title (Type or Print)

Signature of Authorized Person Date

CARGO PREFERENCE REQUIREMENTS 46 U.S.C. 1241/46 CFR Part 381

Use of United States-Flag Vessels - The contractor agrees:

- A.** to use privately owned United States-Flag commercial vessels to ship at least 50 percent of the gross tonnage (computed separately for dry bulk carriers, dry cargo liners, and tankers) involved, whenever shipping any equipment, material, or commodities pursuant to the underlying contract to the extent such vessels are available at fair and reasonable rates for United States-Flag commercial vessels;
- B.** to furnish within 20 working days following the date of loading for shipments originating within the United States or within 30 working days following the date of loading for shipments originating outside the United States, a legible copy of a rated, "on-board" commercial ocean bill-of-lading in English for each shipment of cargo described in the preceding paragraph to the Division of National Cargo, Office of Market Development, Maritime Administration, Washington, DC 20590 and to the FTA recipient (through the contractor in the case of a subcontractor's bill-of-lading.)
- C.** to include these requirements in all subcontracts issued pursuant to this contract when the subcontract may involve the transport of equipment, material, or commodities by ocean vessel.

Analysis. When using Federal funds, the City will ensure that all Federal requirements, required clauses and certifications (including Buy America) are properly followed and included, whether in the State's master intergovernmental contract or in the City's purchase order. The City will obtain Buy America certification, if required, before entering into the purchase order. The overall cost of the SWC, not just the City's purchase price, will be considered in determining which FTA clauses, such as Buy America, will apply to the purchase.

21. Protest Procedures

Any protest to the award of a contract by the City shall be submitted in writing to the Procurement Manager, with a copy to the City Manager, delivered to City of Kingsport, 225 W Center St, Kingsport, Tennessee 37660, not later than five (5) calendar days from the date of City's award decision. The appeal shall, at a minimum, identify the decision in question, specify all reasons why the appealing party disagrees in question, specify all reasons why the appealing party disagrees with the decision, and shall include all facts and justification, including technical information from the appealing party and information or a response from other bidders. So far as practicable, appeals will be decided upon the basis of the written appeal, information and written response submitted by the appealing party and other bidders; all parties are urged to make written submission as complete as possible. Failure of any party to timely respond (within 7 days of request receipt) to a request for information may be deemed by the City that such party does not desire to participate in the proceeding, does not contest the matter, or does not desire to submit a response, and in such event the appeal will proceed and will not be delayed due to the lack of a response.

Upon receipt and review of written submission and any independent investigation deemed appropriate by the City, the City Manager shall either (a) render a decision which shall be final and advise all interested parties of same in writing or (b) at the sole election of the City Manager, conduct an informal hearing at which the interested participating parties will be afforded an opportunity to present their respected position and facts, documents, justification and technical information in support thereof. Parties may, but are not required to be, represented by counsel at the informal hearing, which will not be the subject to formal rules of evidence or procedures. Following the informal hearing, the City Manager shall render a decision which shall be final and advise all interested parties thereof in writing. The City will disclose all information regarding the protest to FTA, and keep FTA informed about the status of the protest.

After exhausting all administrative remedies with the City, any party dissatisfied with the final decision of the City Manager, whether following review of the written submission or informal hearing, may utilize the appeal procedure set forth in Federal Transit Administration Circular 4220 (as amended). Federal Transit Administration (FTA) reviews of protests will be limited to: 1) a grantee's failure to follow its protest procedures, or its failure to review a complaint or protest; or 2) violations of Federal law or regulation, or violations of State/Local law or regulation. FTA will refer violations of Federal law for which it does not have primary jurisdiction to the Federal authority having proper jurisdiction. FTA will refer violations of State or local law to the State or local authority having proper jurisdiction.

**SECTION 9-101
BID PROTESTS**

- (1) **Right to Protest.** Any actual or prospective bidder, offeror, or contractor who is aggrieved in connection with the solicitation or award of a contract may protest to the City Manager. Protestors are urged to seek resolution of their complaints initially with the Procurement Manager. A protest with respect to an invitation for bids or request for proposals shall be submitted in writing prior to the opening of bids or the closing date of proposals, unless the aggrieved person did not know and should not have known of the facts giving rise to such protest prior to bid opening or the closing date for proposals. The protest shall be submitted within five (5) calendar days after such aggrieved person knows or should have known of the facts giving rise thereto.
- (2) **Stay of Procurements During Protests.** In the event of a timely protest under Subsection (1) of this Section, the Procurement Manager shall not proceed further with the solicitation or award of the contract until all the administrative and judicial remedies have been exhausted or until the City Manager makes a determination on the record that the award of a contract without delay is necessary to protect substantial interests of the City.
- (3) **Entitlement to Costs.** In addition to any other relief, when a protest is sustained and the protesting bidder or offeror should have been awarded the contract under the solicitation but is not, then the protesting bidder or offeror shall be entitled to the reasonable costs incurred in connection with solicitation, including bid preparation costs other than attorney's fees.

**SECTION 9-102
CONTRACT CLAIMS**

- (1) **Decision of the Procurement Manager.** All claims by a contractor against the City relating to a contract, except bid protests, shall be submitted in writing to the Procurement Manager for a decision. The contractor may request a conference with the Procurement Manager on the claim. Claims include, without limitation, disputes arising under a contract, and those based upon breach of contract, mistake, misrepresentation or other cause for contract modification or rescission.
- (2) **Notice to the Contractor of the Procurement Manager's Decision.** The decision of the Procurement Manager shall be promptly issued in writing, and shall be immediately mailed or otherwise furnished to the contractor. The decision shall state the reasons for the decision reached, and shall inform the contractor of appeal rights under Subsection (3) of this Section.
- (3) **Finality of Procurement Manager's Decision – Contractor's Right to Appeal.** The Procurement Manager's decision shall be final and conclusive unless, within ten (10) calendar days from the date of receipt of the decision, the contractor mails or otherwise delivers a written appeal to the Board of Mayor and Aldermen or commences an action in a court of competent jurisdiction.

PLEASE COMPLETE AND RETURN
(See Note at Bottom)
Optional Form
Minority Status of Business Ownership
Bidders/Proposers List Information

The City of Kingsport is compiling a Bidders List with information about the minority status of firms bidding on contracts with the City. Please identify your business below, and then complete the Bidders List minority status and income information about your business, by checking ✓ on the applicable line. Information provided will be used only by the City of Kingsport to maintain bidders' records as required per 49 CFR Part 26.11.

Name of Business: _____

City/State of Business Location: _____

Type of Business: _____

Age of Business (years), Since Establishment: _____

1. Business owned (51% or more) by a minority? ____ Yes ____ No
(Minorities include: Women, Black Americans, Hispanic Americans, Native Americans, Asian-Pacific Americans, Subcontinent Asian Americans, or other minorities found to be disadvantaged by the Small Business Administration.)

2. Is business certified by the TNUCP as a Disadvantaged Business Enterprise, and on the current TNUCP Certified DBE Directory? ____ Yes ____ No

Annual Gross Income of Business

____ Less than \$500,000

____ \$500,000 – \$1 million

____ \$1 million – \$2 million

____ \$2 million – \$5 million

____ \$5 million – \$10 million

____ \$10 million – \$15 million

____ \$15 million – \$19.5 million

____ \$19.5 million or above

IF YOU HAVE COMPLETED AND RETURNED THIS FORM TO THE CITY OF KINGSFORT WITHIN THE PAST THREE (3) YEARS, AND YOUR INFORMATION REMAINS UNCHANGED, ENTER ONLY YOUR BUSINESS NAME AND ADDRESS ABOVE and PLEASE CHECK HERE: